

NOTICE

This scan only represents the application as filed. The information contained herein meets the requirements of K.A.R. 5-3-1 or K.A.R. 5-5-1, and has been found acceptable for filing in the office of the Chief Engineer. The application should not be considered to be a complete application as per K.A.R. 5-3-1b or K.A.R. 5-5-2a.

Submit To: CHIEF ENGINEER
Division of Water Resources
Kansas Department of Agriculture
1320 Research Park Drive
Manhattan, Kansas 66502
http://agriculture.ks.gov/dwr

APPLICATION FOR TERM PERMIT

- GROUNDWATER
- SURFACE WATER (check one)

WATER RESOURCES RECEIVED

AUG 25 2021

11:08



State of Kansas

STATUTORY FILING FEE MUST ACCOMPANY THIS APPLICATION
(Make check payable to the Kansas Department of Agriculture)

1. Applicant: (Please print or type)
Name APAC-Kansas Inc., Shears Division
Street 1600 North Lorraine, Suite 1
City and State Hutchinson, KS
Zip Code 67501 Telephone No. (620) 662-3307
E-Mail Address rjerrick@apac.com
Social Security I.D. No. _____
and/or Taxpayer I.D. No. 58-140-1475

2. Location of Point of Diversion:
Sec. 12, Twp. 12S, Rng. 8, (E/W),
Lincoln County, Kansas.
Distance from Southeast Corner of Section:
3,625 feet North from Southeast Corner
850 feet West from Southeast Corner
NOTE: If point of diversion is not site specific (i.e. groundwater pit) show the approximate geographic center.

3. Water Use Data:
Proposed Max. Pumping Rate (gpm) 350
Amount Requested (acre-feet) 100 (32.585 mgy)
per calendar year
Depth of Well (feet) n/a
Date (completed) (will be completed) Oct. 1988
Drainage Basin Saline River Basin
Name of Stream Saline River

4. Water is to be used for (briefly describe proposed use and explain the rate and quantity requested):
Dust control around crushing plant and washing of aggregate. Backup location to 20179073 100 ACFT Max. between both locations
5. Location of place of use:
Access roads in Sections 12, 13, 14 of T125 r8W in Lincoln Co. & washplant near crushing plant
6. Period of use:
Commencing date: 9/11/2021
Ending Date: 9/10/2026 Also enter on Item 12

If off-stream pit, check here .
Will pit floor intersect water table? Yes No

7. Location of the proposed point of diversion and those of other water users within 1/2 mile shall be indicated on the diagram to the lower-left, scale 1 inch = 2,000 feet. If surface water, indicate on the diagram the course of the stream, and its name. List other D.W.R. permit numbers that cover the requested point(s) of diversion or place of use here:
20169073

FEE SCHEDULE

- 1. The filing fee for an application is based on the maximum amount of water use proposed within a year. Except for storage, the fee is:
Acre-feet Fee
0-100 \$200.00
101-320 \$300.00
More than 320 \$300.00
plus \$20 for each additional 100 acre-feet or any part thereof.
- 2. The fee for an application in which storage is requested, is:
Acre-feet Fee
0-250 \$200.00
More than 250 \$200.00
plus \$20.00 for each additional 250 acre-feet of storage or any part thereof.

- NOTE: If an application requests both direct use and storage, the fee charged shall be as determined under No. 1 or No. 2 above, whichever is greater, but not both fees.
- 3. A request for an extension of time to extend the term of a term permit shall be accompanied by a fee of \$100.00.
- 4. There is a separate application form for domestic use. Do not use this form for domestic use.

CONVERSION FACTORS

1 acre-foot equals 325,851 gallons
1 million gallons equal 3.07 acre-feet

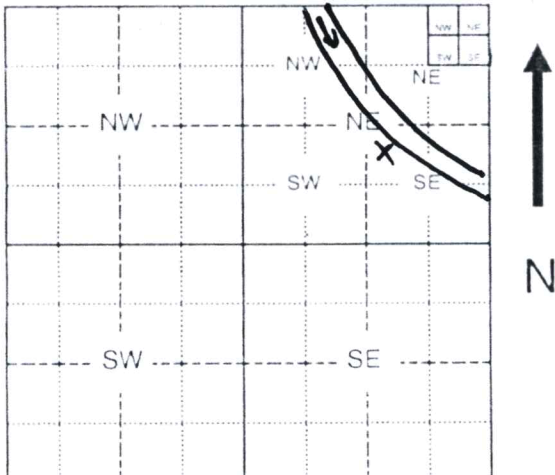

8/30/2021
L Moody

Assisted by _____

For Office Use Only:
F.O. 3 GMD Meets K.A.R. 5-3-1 (YES/NO) Use IND Source G/S County LN By BMM Date 8/25/21
Code TRP Fee \$ 200 TR # _____ Receipt Date 8-25-2021 Check # 6900115568

8. For groundwater use, list below all wells within 1/2 mile of the proposed well, and plot locations upon the diagram on reverse side. If additional space is needed, attach a map.

Other wells -

Well A Owner(s): _____
Address: _____

Well B Owner(s): _____
Address: _____

9. For surface water use, list below the names and addresses of all landowners from a point 1/2 mile upstream to a point 1/2 mile downstream of the tract of land upon which the point of diversion is located. If additional space is needed, attach sheet.

Tract A Owner(s): See attachment
Address: _____

Tract B Owner(s): _____
Address: _____

10. The owner of the point of diversion, if other than the applicant is (please print):

(name, address and telephone number)

You must provide evidence of legal access to, or control of, the point of diversion from the landowner or the landowner's authorized representative. Provide a copy of a recorded deed, lease, easement or other document with this application. In lieu thereof, you may sign the following sworn statement:

I have legal access to, or control of, the point of diversion described in this application from the landowner or the landowner's authorized representative. I declare under penalty of perjury that the foregoing is true and correct.

Executed on August 19, 2021. _____
Applicant's Signature

The applicant must provide the required information or signature irrespective of whether they are the landowner. Failure to complete this portion of the application will cause it to be unacceptable for filing and the application will be returned to the applicant.

11. The applicant states that the information set hereon is true and accurate to the best of his/her knowledge.

12. The applicant agrees to waive any right to a hearing on the matter of abandonment of this appropriation right and further agrees that this appropriation right may be dismissed and terminated upon completion of the proposed project, said dismissal date to be on August 19, 2021 or within any extension of time authorized by the Chief Engineer, Division of Water Resources, Kansas Department of Agriculture.

13. The applicant agrees to provide water to nearby water users, at no charge to said users, should their rights to use water become impaired by the project proposed by this application.

14. Water use contact person (in event emergency contact is needed):

Name: Rick White Telephone No. (785) 524-4413

Signature of Applicant or _____
Rod Jerrick Authorized Representative 8/19/2021
Date
Rod Jerrick Material Sales Representative
Applicant's Name Printed Title

DO NOT WRITE BELOW THIS LINE

CONDITIONS OF APPROVAL:

The applicant shall maintain accurate and complete records from which the quantity of water diverted during each calendar year may be readily determined. Accurate and complete records shall be furnished to the Chief Engineer by March 1 following the end of each calendar year. Failure to file the annual water use report by the due date, shall cause the applicant to be subject to a civil penalty.

The use of water herein authorized shall not be made so as to impair any use under existing water rights nor prejudicially and unreasonably affect the public interest.

The Chief Engineer specifically retains jurisdiction in this matter with authority to make such reasonable reductions in the approved rate of diversion and quantity authorized, and such changes in other terms, conditions, and limitation set forth in this approval and permit to proceed as may be deemed to be in the public interest.



APAC - Kansas, Inc.
Shears Division
Materials Branch
P.O. Box 1605
Hutchinson, KS 67504
(620) 662-3307 ext. 132

Term Permit Application – Attached Sheet

Owners that are within ½ mile of point of diversion.

9. Upstream from point of diversion

Owner(s): Tim Meier
Address: 1533 N. 195th Road; Lincoln, KS 67455

Owner(s): Patricia Rackley
Address: 3580 E. Country Club Road; Salina, KS 67401

Downstream from point of diversion

Owner(s): Tim Meier
Address: 1533 N. 195th Road; Lincoln, KS 67455

Owner(s): James Weber
Address: 923 N. 5th Street; Lincoln, KS 67455

WATER RESOURCES
RECEIVED

AUG 25 2021

KS DEPT OF AGRICULTURE



APAC - Kansas, Inc.
Shears Division
Materials Branch
P.O. Box 1605
Hutchinson, KS 67504
(620) 662-3307 ext. 132

August 23, 2021

Kansas Department of Agriculture
Division of Water Resources
1320 Research Park Drive
Manhattan, KS 66502

RE: Term Permit: Well

Dear Chief Engineer:

Attached is the application and payment for replacement of Quartzite Quarry expiring term permit number 20169073. If you have any questions, please contact me at (620) 662-3307 ext. 132.

Sincerely,

Rod Jerrick
APAC-KS
Shears Division
Materials Branch

WATER RESOURCES
RECEIVED

AUG 25 2021

KS DEPT OF AGRICULTURE

DATA ENTRY SYSTEM ID NUMBER SHEET

FILE NUMBER 20219061

APPLICANT PERSON ID & SEQ #	49889	PDIV ID	BATTERY ID
54665			

LANDOWNER PERSON ID & SEQ #	40229	PUSE ID
54665		

WATER USE CORRESPONDENT PERSON ID & SEQ #
54665