

Kansas Department of Agriculture  
Division of Water Resources  
**PERMIT OF NEW APPLICATION WORKSHEET**

1. File Number: <p style="text-align: center; font-size: 1.2em;"><b>50,795</b></p>	2. Status Change Date: <p style="text-align: center; color: blue; font-size: 1.2em;"><b>8/28/2023</b></p>	3. Field Office: <p style="text-align: center; font-size: 1.2em;"><b>01</b></p>	4. GMD: <p style="text-align: center; font-size: 1.2em;"><b>0</b></p>
---	--	--	--

5. Status:     Approved                       Denied by DWR/GMD                       Dismiss by Request/Failure to Return

6. Enclosures:     Check Valve             N of C Form             Water Tube             Driller Copy             Meter

<p>7a. Applicant(s)                      Person ID <b>68270</b> New to system <input type="checkbox"/>                      Add Seq# _____</p> <p style="margin-top: 20px;"><b>BOBBY GLOVER</b> <b>2479 US HWY 400</b> <b>MCCUNE, KS 66753</b></p>	<p>7c. Landowner(s)                      Person ID _____</p>
<p>7b. Landowner(s)                      Person ID <b>62113</b> New to system <input type="checkbox"/>                      Add Seq# <b>1</b></p> <p style="margin-top: 20px;"><b>GLOVER REAL ESTATE LLC</b> <b>PO BOX 3823</b> <b>BLUFFTON, SC 29910</b></p>	<p>7e. Miscellaneous                      Person ID _____</p>

<p>8. WUR Correspondent                      Person ID <b>68270</b> New to system <input type="checkbox"/>                      Add Seq# _____ Overlap File (s) WUC                      Notarized WUC Form <input type="checkbox"/> Agree <input type="checkbox"/> Yes <input type="checkbox"/> No</p> <p style="margin-top: 20px;"><b>7a.</b></p>	<p>9. Use of Water:    Changing?    <input type="checkbox"/> Yes    <input checked="" type="checkbox"/> No</p> <p style="margin-left: 40px;"><input type="checkbox"/> Groundwater                      <input checked="" type="checkbox"/> Surface Water</p> <p style="margin-left: 40px;"><input type="checkbox"/> IRR                      <input checked="" type="checkbox"/> REC                      <input type="checkbox"/> DEW                      <input type="checkbox"/> MUN</p> <p style="margin-left: 40px;"><input type="checkbox"/> STK                      <input type="checkbox"/> SED                      <input type="checkbox"/> DOM                      <input type="checkbox"/> CON</p> <p style="margin-left: 40px;"><input type="checkbox"/> HYD DRG                      <input type="checkbox"/> WTR PWR                      <input type="checkbox"/> ART RECHRG</p> <p style="margin-left: 40px;"><input type="checkbox"/> IND SIC: _____                      <input type="checkbox"/> OTHER: _____</p>
---	--

10. Completion Date: 12/31/2024                      11. Perfection Date: 12/31/2028                      12. Exp Date: \_\_\_\_\_

13. Conservation Plan Required?  Yes  No Date Required: \_\_\_\_\_ Date Approved: \_\_\_\_\_ Date to Comply: \_\_\_\_\_

14. Water Level Measuring Device?  Yes  No Date to Comply: \_\_\_\_\_ Date WLMD Installed: \_\_\_\_\_

<p style="color: blue; font-size: 1.2em;">8/30/2023</p> <p style="color: blue; font-size: 1.2em;">LMoody</p>	<p>Date Prepared: <b>8/23/2023</b>                      By: <b>LHH</b></p> <p>Date Entered: <b>8/30/2023</b>                      By: _____</p> <p>Date Reviewed: 8/24/23                      By: <b>JDK</b></p>	
--	---	--

File No. **50,795**      15. Formation Code:      Drainage Basin: **NEOSHO RIVER**      County: **LB**      Special Use:      Stream: **LITTLE LABETTE CREEK**

16. Points of Diversion										17. Rate and Quantity					
MOD	DEL	ENT	PDIV	Qualifier	S	T	R	ID	'N	'W	Authorized		Additional		
											Rate gpm	Quantity af	Rate gpm	Quantity af	Overlap PD Files
<b>MOD</b>			<b>89572</b>	<b>NW SW NE</b>	<b>30</b>	<b>31S</b>	<b>20E</b>	<b>1</b>	<b>3930</b>	<b>2037</b>	<b>10,000</b>	<b>106</b>	<b>10,000</b>	<b>106</b>	<b>NONE</b>

18. Storage: Rate \_\_\_\_\_ NF      Quantity \_\_\_\_\_ ac/ft      Additional Rate \_\_\_\_\_ NF      Additional Quantity \_\_\_\_\_ ac/ft

19. Limitation: \_\_\_\_\_ af/yr at \_\_\_\_\_ gpm ( \_\_\_\_\_ cfs) when combined with file number(s) \_\_\_\_\_  
 Limitation: \_\_\_\_\_ af/yr at \_\_\_\_\_ gpm ( \_\_\_\_\_ cfs) when combined with file number(s) \_\_\_\_\_

20. Meter Required?  Yes  No      To be installed by **12/31/2024**      Date Acceptable Meter Installed \_\_\_\_\_

21. Place of Use										NE¼								NW¼				SW¼				SE¼				Total	Owner	Chg? <b>NO</b>	Overlap Files
MOD	DEL	ENT	PUSE	S	T	R	ID	NE ¼	NW ¼	SW ¼	SE ¼	NE ¼	NW ¼	SW ¼	SE ¼	NE ¼	NW ¼	SW ¼	SE ¼	NE ¼	NW ¼	SW ¼	SE ¼										
<b>MOD</b>			<b>70807</b>	<b>30</b>	<b>31S</b>	<b>20E</b>	<b>1</b>	<b>MARSH (SE) (SW NE)</b>																	<b>7b</b>	<b>NO</b>	<b>50897</b>						

Comments:

**KANSAS DEPARTMENT OF AGRICULTURE**  
**Division of Water Resources**

**M E M O R A N D U M**

**TO:** Files

**DATE:** August 18, 2023

**FROM:** Lloyd Hemphill

**RE:** New Application, File Nos. 50,795 and  
50,897

Bobby Glover (Glover Real Estate LLC) has filed the new applications referenced above proposing to appropriate surface water for recreational use in a marsh located in the Southeast Quarter (SE $\frac{1}{4}$ ) and the Southwest quarter of the Northeast Quarter of (SW $\frac{1}{4}$  of the NE $\frac{1}{4}$ ) Section 30, in Township 31 South, Range 20 East, Labette County, Kansas. Both applications will share the same place of use which is owned by the applicant.

The marsh was designed by the USDA-NRCS as an ACEP – Wetland Reserve project. The plans show six individual marsh pools and a micro-depression zone which will store a small amount of water. The micro-depression zone covers about 8 acres with about 3 small pools per acre (0.05 acre surface area each). The maximum excavated depth of these depressions is between 1 and 1.5 feet and the total storage capacity is about 1 acre-foot. The dimensions of all these structures are described in the following table:

	Surface Area (acres)	Capacity (acre-feet)	Average Depth (inches)
Dike 1	4.71	3.65	9.3
Dike 2	16.01	12.72	9.5
Dike 3	3.63	2.63	8.7
Dike 4	2.11	2.16	12.3
Dike 5	1.02	1.14	13.4
Dike 6	6	5.09	10.2
Micro-depression	1.5	2	16
<b>Total</b>	<b>35</b>	<b>29.4</b>	<b>10.1</b>

**File No. 50,795 – Direct diversion**

This application proposes to appropriate 106 acre-feet of surface water at a diversion rate of 10,000 gallons per minute from one pumpsite on Little Labette Creek (Neosho River). This application will allow water to be pumped directly from the creek (when flows are adequate, and permission is granted). The water will be used to fill and maintain water levels in the marsh (i.e. offset evaporative and seepage losses). The proposed point of diversion (pumpsite) is located in the Northwest Quarter of the Southwest Quarter of the Northeast Quarter (NW $\frac{1}{4}$  SW $\frac{1}{4}$  NE $\frac{1}{4}$ ) of Section 30, in Township 31 South, Range 20 East, Labette County, Kansas. This direct diversion will be primarily used to fill the six marsh pools but would rarely be used in the micro-depression area.

The applicant's consulting engineer, Brian Severin of Sustainable Environmental Consultants, provided further description of the management practices typically followed for similar projects. Actual wetland cell operation varies by location, manager, and season. The wetland will not be managed the same every year. The water level in the wetland cells is managed to best attract wildlife and migratory waterfowl at various times of the year. Water level will be used to control vegetation and feed sources. Typically, wetland cells are filled prior to the waterfowl season.

There may be releases and additional pumping throughout the hunting season to create a water profile for the specific species and hunting experience. The wetland cells are often drained following the hunting season for dike and storage area maintenance. Some undesirable vegetation is often best managed by flooding, therefore additional pumping may be used to manage vegetation. Pumping will help maintain soil saturation throughout the year as well. Minimal seepage is anticipated in the floodplain soils, especially since soil saturation will be maintained throughout the year. The wetland may be pumped full (if precipitation/runoff is not adequate) and water released more than once a year.

The intention for this application was to allow enough water to fill the marsh three times (3 X capacity) and cover one year of net evaporation. However, the originally requested quantity of water (277.32 AF) was based on the storage capacity at the top of dike elevation rather than the more realistic capacity at the auxiliary spillway. The requested quantity was modified to 106 acre-feet to reflect a more realistic number. The net evaporation in this area is 6 inches per year resulting in a total evaporation of 17.5 acre-feet (6 in/yr X 1 yr X 35 ac.) The requested quantity is justified as:  $3 \times 29.4 \text{ AF (capacity)} + 17.5 \text{ AF (evaporation)} = 106 \text{ AF}$ . This equates to a total of about three feet of water per year per unit of marsh surface area. The applicant did not specifically request a quantity for seepage, however, some of this water would be available to cover any seepage loss encountered if it is not necessary to fill and release water from the marsh three times. As modified, the requested quantity appears reasonable for this project.

This approval will be subject to specific conditions, which stipulate strict requirements for direct surface water diversion. These conditions include the stipulation that no diversion shall occur unless there is water available to satisfy all demands by senior water rights and permits, written or verbal permission from the Chief Engineer, or an authorized representative is required prior to diverting water, and streamflow cannot be stopped at the first riffle below the point of diversion while diversion is taking place. The application also complies with K.A.R 5-3-15 (c)(5) because the proposed use of water for recreational use is typically during the fall season, and there is no need for direct diversion of water from July 1 through September 30.

#### **File No. 50,897 – Natural Flow Storage**

Several of the pools related to this project are nested together in essentially the same drainage area. The combined capacity of these pools is greater than 15 acre-feet. Since natural flows/runoff will be collected and stored within these pools, an additional permit is required for this appropriation. Duplicate applications were originally filed proposing direct diversion for this site (File Nos. 50,795 & 50,897). Application, File No. 50,897 was modified to cover the natural flow storage, instead.

This application proposes to collect 106 acre-feet of natural flows in the marsh. The proposed points of diversion are six water control structures at low points in each pool. No point of diversion was defined for the micro-depression area due to the small size of these pools. The points of diversion are located in the Southeast (SE¼) Quarter of Section 30, in Township 31 South, Range 20 East, Labette County, Kansas, as described on the application. The source of water will be designated as Little Labette Creek Trib 4 (Neosho), although there is no discrete stream in the area.

Typically, similar applications request a quantity equal to the storage capacity of the marsh plus net evaporation. However, more quantity is justified because this structure may be filled and the water released more than once (provided that natural flows are available), depending on the needed management strategy. This application requests 106 acre-feet with the same justification as File No. 50,795. A reasonable quantity will be determined upon certification.

The points of diversion proposed by both applications are located on land owned by the applicant. The applicant submitted a signed supplemental page on July 3, 2023 (for File No. 50,795) and a signed statement on the application (File No. 50,897) indicating legal access to the points of diversion. No other files overlap these points of diversion.

Notification letters were sent to landowners upstream and downstream of the pumpsite (File No. 50,795) on June 9, 2023. Notification letters for File No. 50,897 were sent to upstream and downstream landowners on July 14, 2023. Three phone calls were received with general questions and comments, but nothing to indicate impairment. Jon Murray has used the creek for around thirteen years to water about twenty pairs of cattle downstream of the proposed pumpsite. According to Mr. Murray, there has been sufficient water for the cattle in the Fall season except for 2022 when the creek was dry. Standard permit conditions were discussed with Mr. Murray, and he did not provide further concerns. There are no other permitted water rights within two miles of these files. Approval of this application will not impair senior water rights.

The existing wetlands were reviewed by DWR Structures under WSN: LLB-97 in 2018. This project was determined non-jurisdictional to Structures permitting. Additional permitting is not required as long as no modifications are made to existing berms (maintenance, repairs, raising, etc.) or additional berms are planned.

The wetland project was originally designed by United States Department of Agriculture, Natural Resources Conservation Service (USDA-NRCS) using ACEP - Wetland Reserve Easement (WRE) funding. The property remains a WRE easement. A Compatible Use Agreement (CUA) was provided by Brent Turney, NRCS on August 15, 2022. The wetland was constructed in the Summer/Fall of 2020

The proposed point of diversion is located on a tributary stream that joins the Neosho River below the Minimum Desirable Streamflow (MDS) gage near Parsons so this permit will not be subject to MDS administration and streamflows at this gage.

In accordance with K.S.A. 82a-706c, the Chief Engineer retains full authority to require any water user to install meters, gages, or other measuring devices, which devices he or she or his or her agents may read at any time. Water flowmeter requirements are further described in K.A.R. 5-1-4 through K.A.R. 5-1-12.

Brett Bunger, Water Commissioner, Topeka Field Office, recommended in an August 23, 2023 e-mail that the referenced new application should be approved. Based on the above discussion, the area remains open to new appropriations, the approval of File No. 50,795 is subject to specific conditions relative to direct surface water diversions, diversion is typically limited to fall "off-season" pumping, the project is properly permitted by the Structures Program, and there is no indication that existing water rights will be impaired, it is recommended that the referenced application be approved.

Lloyd Hemphill  
Environmental Scientist  
Topeka Field Office



THE STATE OF KANSAS

KANSAS DEPARTMENT OF AGRICULTURE  
Mike Beam, Secretary of Agriculture

DIVISION OF WATER RESOURCES  
Earl D. Lewis Jr., Chief Engineer

**SWORN STATEMENT**  
**PURSUANT TO K.S.A. 82a-709**

You must provide evidence of legal access to, or control of, the point of diversion from the landowner or the landowner's authorized representative. Provide a copy of a recorded deed, lease, easement or other document with this application. In lieu thereof, you may sign the following sworn statement:

I have legal access to, or control of, the point of diversion described in this application from the landowner or the landowner's authorized representative. I declare under penalty of perjury that the foregoing is true and correct.

Executed on 6-26, 2023.

[Signature]  
Applicant's Signature

The applicant must provide the required information or signature irrespective of whether they are the landowner. Failure to complete this portion of the application will cause it to be unacceptable for filing and the application will be returned to the applicant.

RECEIVED  
JUL 03 2023  
Topeka Field Office  
DIVISION OF WATER RESOURCES

## Hemphill, Lloyd [KDA]

---

**From:** Bunger, Brett [KDA]  
**Sent:** Wednesday, August 23, 2023 12:32 PM  
**To:** Hemphill, Lloyd [KDA]  
**Subject:** RE: Application, File No. 50795 & 50897: For your recommendation

Lloyd, good work on the memo. I have no objections to approving these applications.

Brett

---

**From:** Hemphill, Lloyd [KDA] <Lloyd.Hemphill@ks.gov>  
**Sent:** Friday, August 18, 2023 4:28 PM  
**To:** Bunger, Brett [KDA] <Brett.Bunger@ks.gov>  
**Subject:** Application, File No. 50795 & 50897: For your recommendation

Brett,

Will you provide your recommendation on this package of applications? This is a pair of REC use marsh apps for direct diversion & natural flow next to Little Labette Creek, just south of Parsons.

Thanks,  
Lloyd

Lloyd Hemphill, Environmental Scientist  
Kansas Department of Agriculture  
Division of Water Resources, Topeka Field Office  
1131 SW Winding Rd, Suite 400  
Topeka, KS 66615  
Office: (785) 296-5733

Kansas

Owner: Dale & Joyce Ann Fultz Revocable Trust

Practice: ACEP - Wetland Reserve Easement (WRE)

County: Labette

Legal: SE 1/4 Sec 30, T-31S; R-20E

Index to Drawings

Sheet No.	Description
1	Cover Sheet
2	Location Map and Table of Quantities
3	Orthographic Plan Map
4	Site Preparation Map
5	Sediment Control Detail
6	Dike 1 Detail
7	Dike 1 Detail
8	Dike 2 Detail
9	Dike 2 Detail
10	Dike 3 Detail
11	Dike 3 Detail
12	Dike 4 Detail
13	Dike 4 Detail
14	Dike 5 Detail
15	Dike 5 Detail
16	Dike 6 Detail
17	Dike 6 Detail
18	Seeding Plan Map

Before any investigation or construction activity, the excavator is responsible for calling Kansas One-Call at 800-344-7233 (800-DIG-SAFE) or 811

Brian W. Severin June 2018  
Designed by Date

I certify that the plans and detailed specifications for this project were developed in accordance with the policies and procedures of the Natural Resources Conservation Service.



Approved by \_\_\_\_\_ Date \_\_\_\_\_

Revisions		
PAGE NUMBERS	APPROVED	DATE



Table of Quantities			
Item	Unit	Design Quantity	As-Built Quantity
Site Preparation – Mowing	acre	113.0	
Sediment Control	lin ft	500	
Excavation			
Microdepression Zone	acre	7	
Borrow Area 1	cu yd	4,590	
Dike 1 Foundation Stripping	cu yd	1,285	
Borrow Area 2	cu yd	5,505	
Dike 2 Foundation Stripping	cu yd	1,470	
Borrow Area 3	cu yd	1,625	
Dike 3 Foundation Stripping	cu yd	700	
Borrow Area 4	cu yd	2,130	
Dike 4 Foundation Stripping	cu yd	560	
Borrow Area 5	cu yd	790	
Dike 5 Foundation Stripping	cu yd	405	
Borrow Area 6	cu yd	5,650	
Dike 6 Foundation Stripping	cu yd	1,285	
Earthfill			
Dike 1 *	cu yd	4,720	
Dike 2 *	cu yd	4,940	
Dike 3 *	cu yd	2,335	
Dike 4 *	cu yd	2,365	
Dike 5 *	cu yd	1,850	
Dike 6 *	cu yd	4,920	
Water Control Structure (3' tall)	each	3	
Water Control Structure (4' tall)	each	3	
8" SDR 35 PVC Pipe	lin ft	355	
Bar Guard, 8" Dia. Pipe	each	6	
Critical Area Planting and Mulching	acre	8.8	
Chemical Weed Control	acre	74.3	
Range Planting	acre	74.3	

\* Includes earthfill volume of dike plus foundation stripping

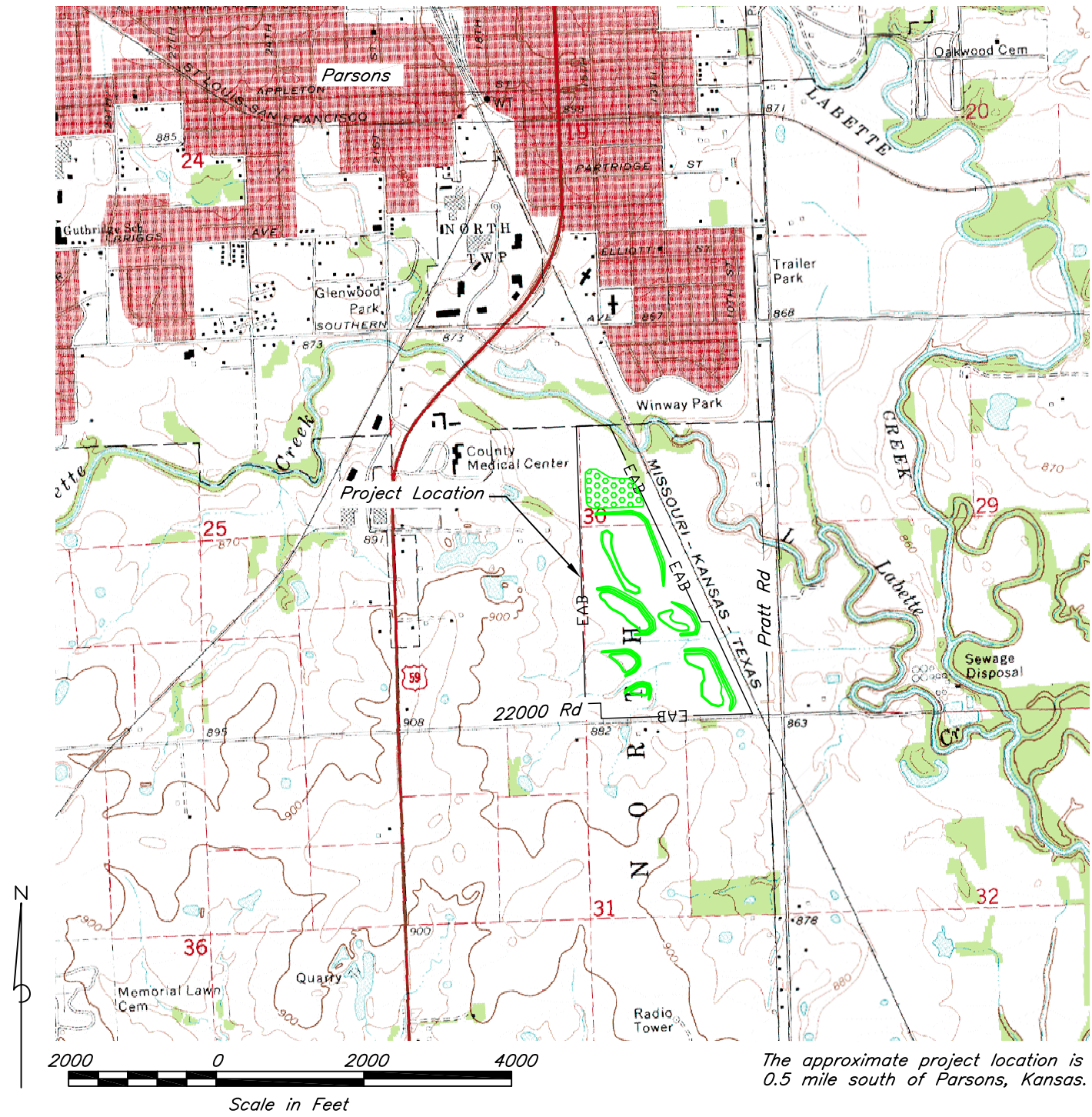

Location Map and Table of Quantities

Date 06/18  
 Designed B Severin  
 Drawn B Severin  
 Checked K Buntin  
 Approved B Severin

Dale & Joyce Ann Fultz Revocable Trust  
 ACEP – Wetland Reserve Easement  
 SE 1/4 Sec 30, T-31S; R-20E  
 Labette County, Kansas

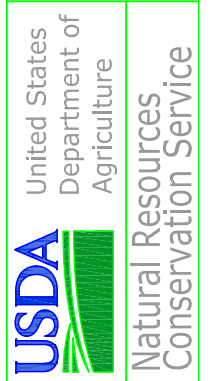

Drawing Name fultz30  
6/25/18 2:02 PM  
 Sheet 2 of 18

- Microdepression Zone Construction Notes:**
1. Excavate three (3) depressions per acre. Total number of depressions for this project is 21.
  2. Depression locations will be as directed by NRCS inspector. Depressions shall not be within 100 feet center to center from one another.
  3. Microdepressions shall have a bottom area of approximately 1,500 square feet.
  4. Total excavated depth shall be 1.0 foot (min.) to 1.5 feet (max.).
  5. Excavated material shall be spoiled down gradient of the depression. Fill heights shall not exceed 1.0 foot.
  6. Microdepression and spoil area side slopes shall be 10:1 or flatter.

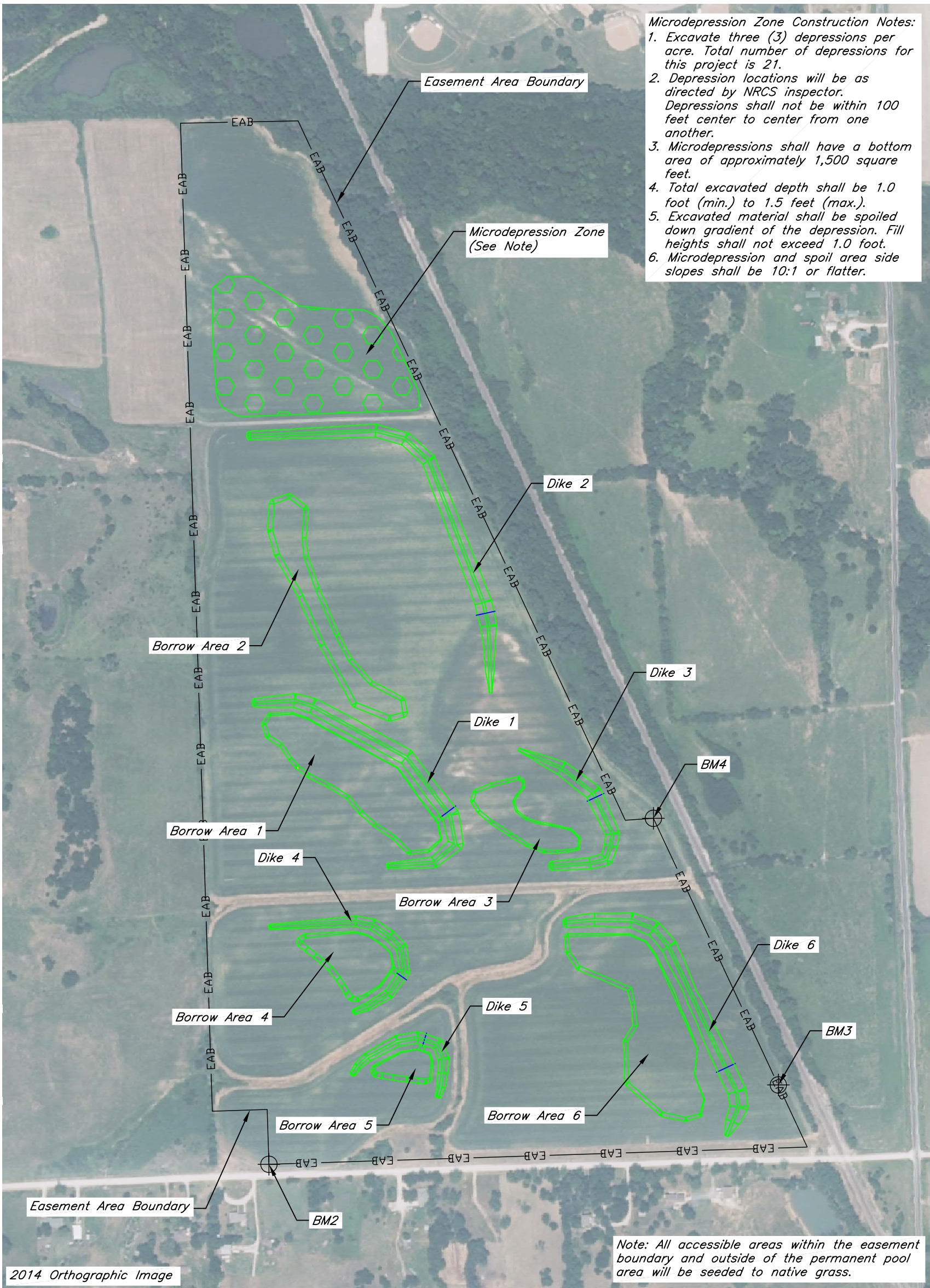

Note: All accessible areas within the easement boundary and outside of the permanent pool area will be seeded to native grass.

Benchmark Table				
Benchmark	Northing	Easting	Elevation	Description
BM1	1563649.57	2258154.51	858.52	Top of survey cap 29 (Larry C. Allen Revocable Trust)
BM2	1563388.24	2255024.50	877.56	Top of survey cap 1
BM3	1563690.15	2256963.24	861.34	Top of survey cap 33
BM4	1564706.10	2256486.65	861.44	Top of survey cap 29

*Orthographic Plan Map*

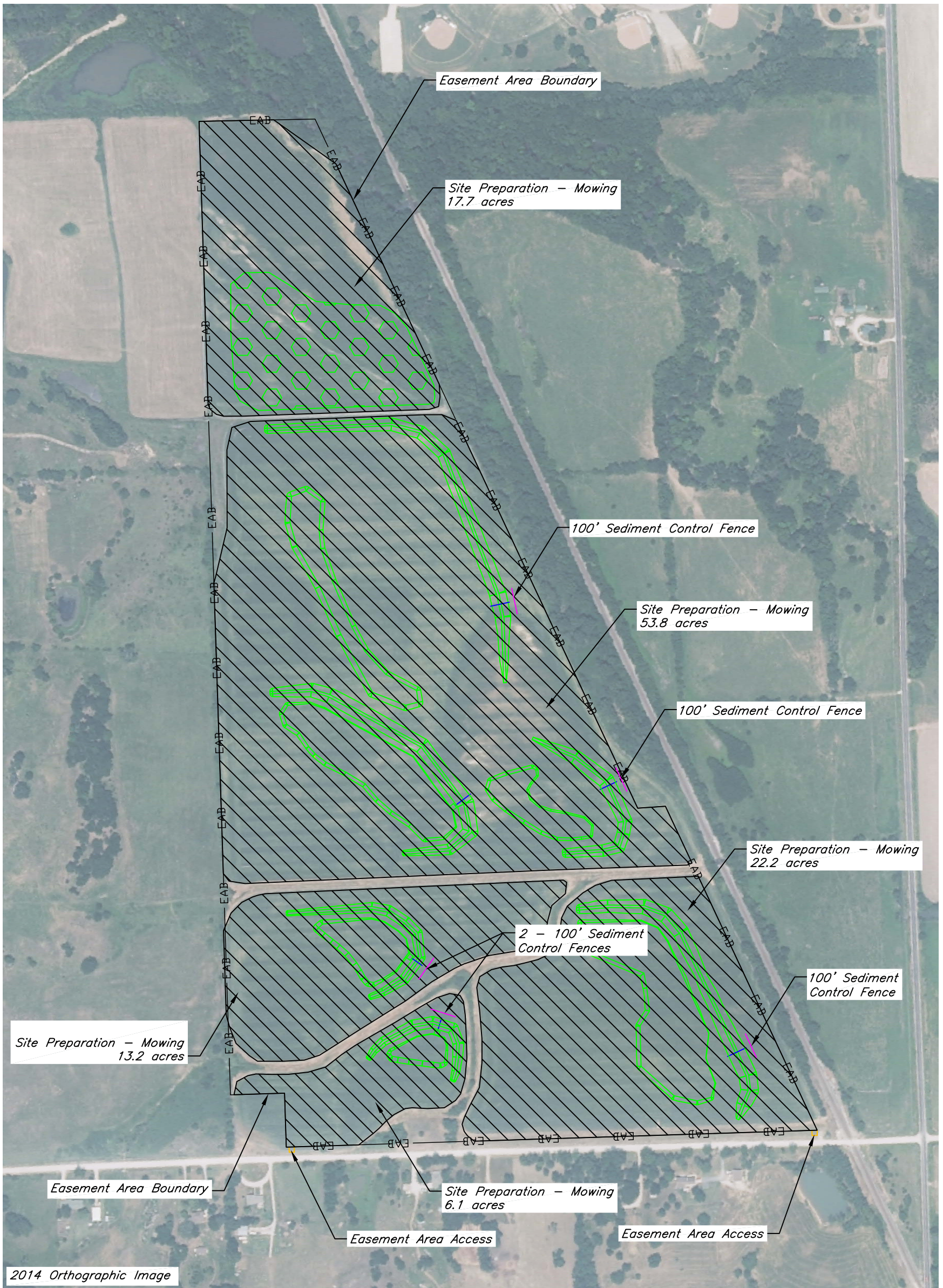

Site Preparation Map

**GENERAL NOTES FOR SILT FENCE:**

1. Posts are to be installed on the downhill side of the geotextile.
2. Backfill anchor trench with compacted soil or gravel.
3. Install silt fence along contour lines, with a short section turned upgrade at each end of the barrier.
4. Where possible, lay out the silt fence 5.0 ft to 6.0 ft beyond the toe of the slope.
5. Extend the bottom 12" of the filter fabric to line the front and bottom of the trench.
6. Maintain a properly functioning silt fence throughout the duration of the project or until disturbed areas have been vegetated.
7. Remove sediment as it accumulates and place it in a stable area approved by the engineer.
8. Fasteners: The geotextile may be attached to the posts using geotextile pockets, staples, or nails. Staples shall be no. 17 gauge minimum and shall have a minimum 0.75 in. wide crown and 0.5 in. long legs. Nails shall be a minimum of 14 gauge, 1 inch long, with 0.75 in. button heads. Spacing shall be 6" maximum.
9. When joints are necessary, geotextile shall be spliced together at a support post with a minimum overlap of 18 inches, and securely sealed.

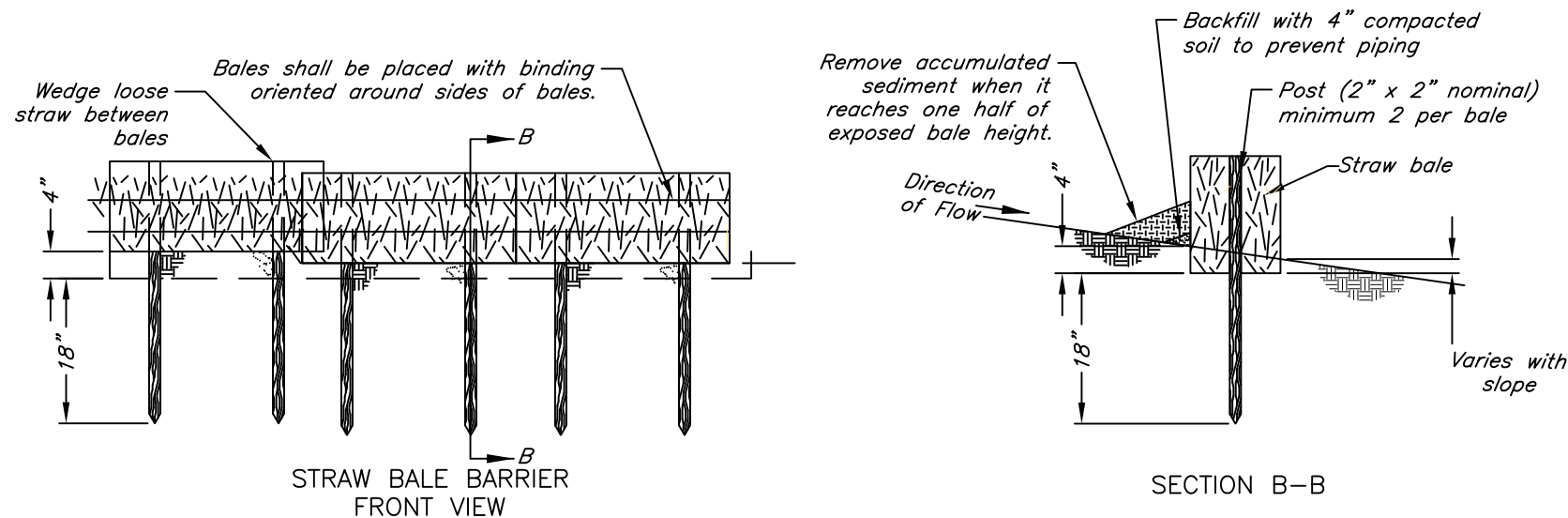
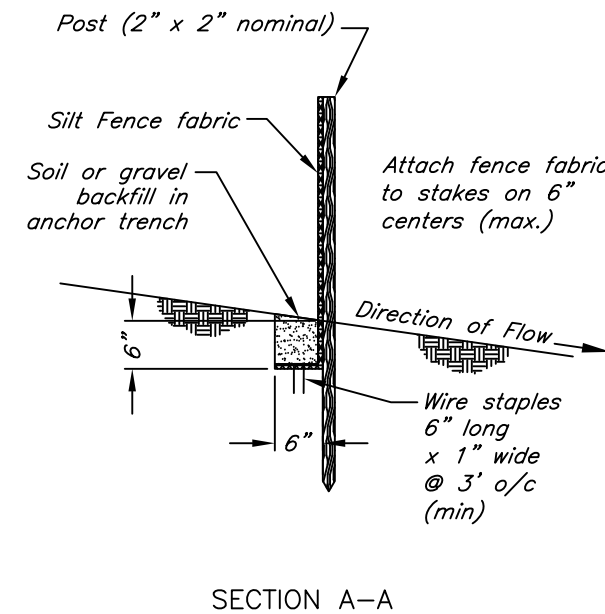
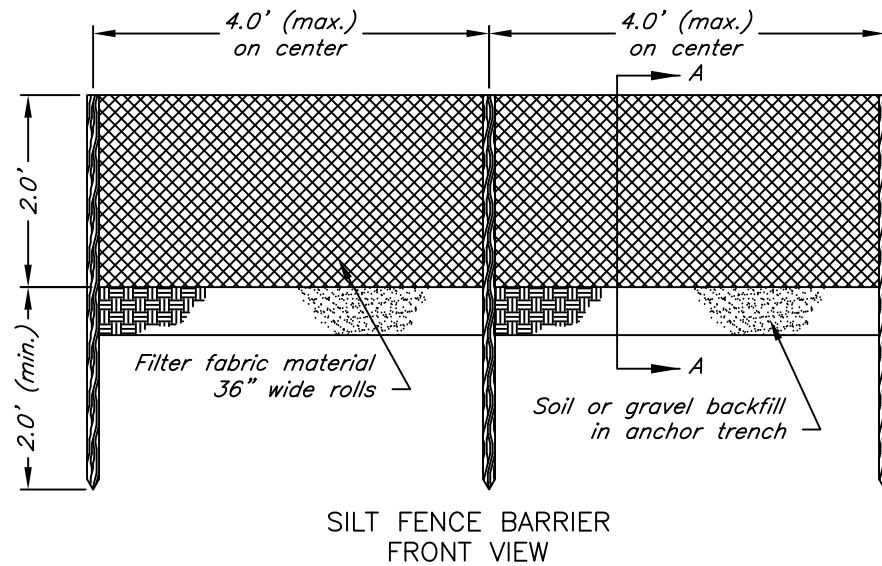
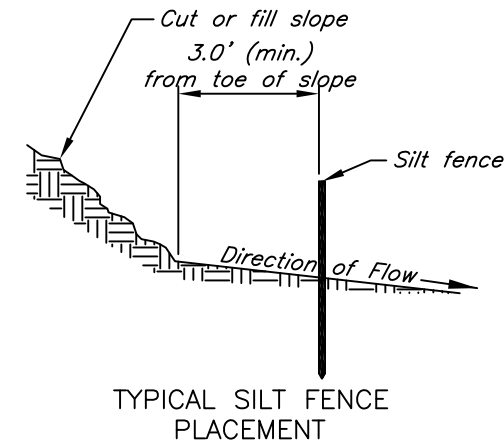

**GENERAL NOTES FOR BALE BARRIERS:**

1. Bales shall be placed in a single row on the contour, with ends of adjacent bales tightly abutting one another.
2. All bales shall be either wire-bound or string-tied.
3. Straw bales shall be installed so that binding is oriented around the sides rather than along the tops and bottoms of the bales.
4. The straw bale barrier shall be installed in a trench excavated to the width of the bale and to a minimum uphill depth of 4 inches.
5. Each bale shall be anchored by at least two stakes each having minimum dimensions of 2" x 2" x 36". The first stake in each bale shall be driven toward the previously laid bale to force the bales together.
6. Gaps between adjacent bales shall be packed with straw.
7. Remove sediment as it accumulates and place it in a stable area approved by the engineer.
8. The use of bales containing noxious weeds will not be permitted.

Date	06/18
Designed	B Severin
Drawn	B Severin
Checked	K Buntin
Approved	B Severin

Dale & Joyce Ann Fultz Revocable Trust  
ACEP - Wetland Reserve Easement  
SE 1/4 Sec 30, T-31S; R-20E  
Labette County, Kansas

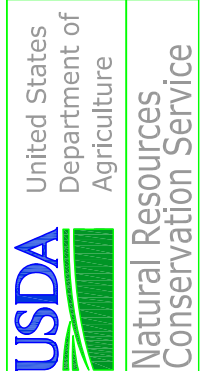

Drawing Name  
fultz30  
6/25/18 2:02 PM  
Sheet 5 of 18

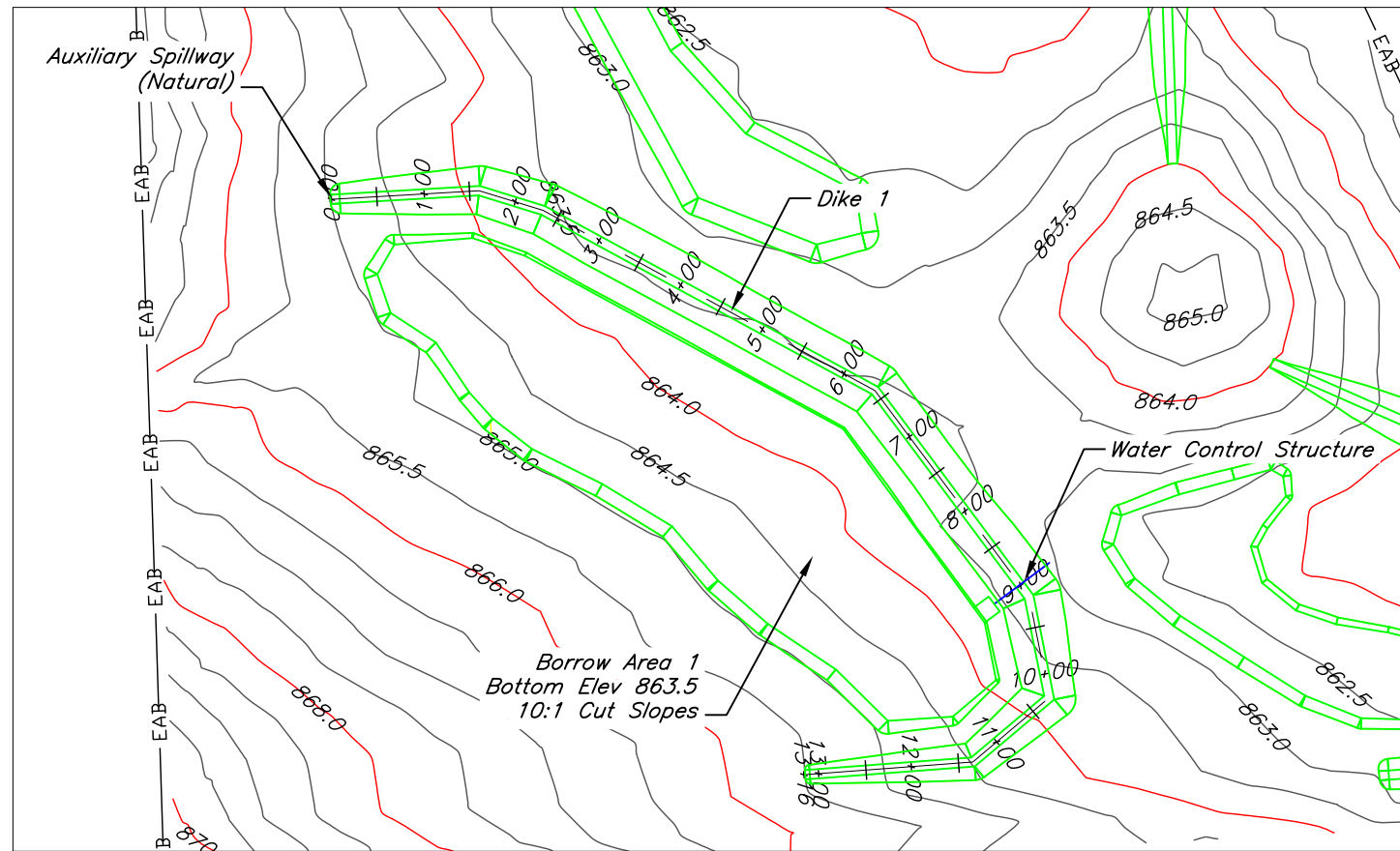

Elevation (ft)	Area (ac)	Total Storage (ac-ft)
863.5	0.00	0.00
864.0	1.73	0.43
864.5	3.21	1.67
ASW 865.0	4.71	3.65
865.5	6.37	6.42
TOD 866.0	7.69	9.93

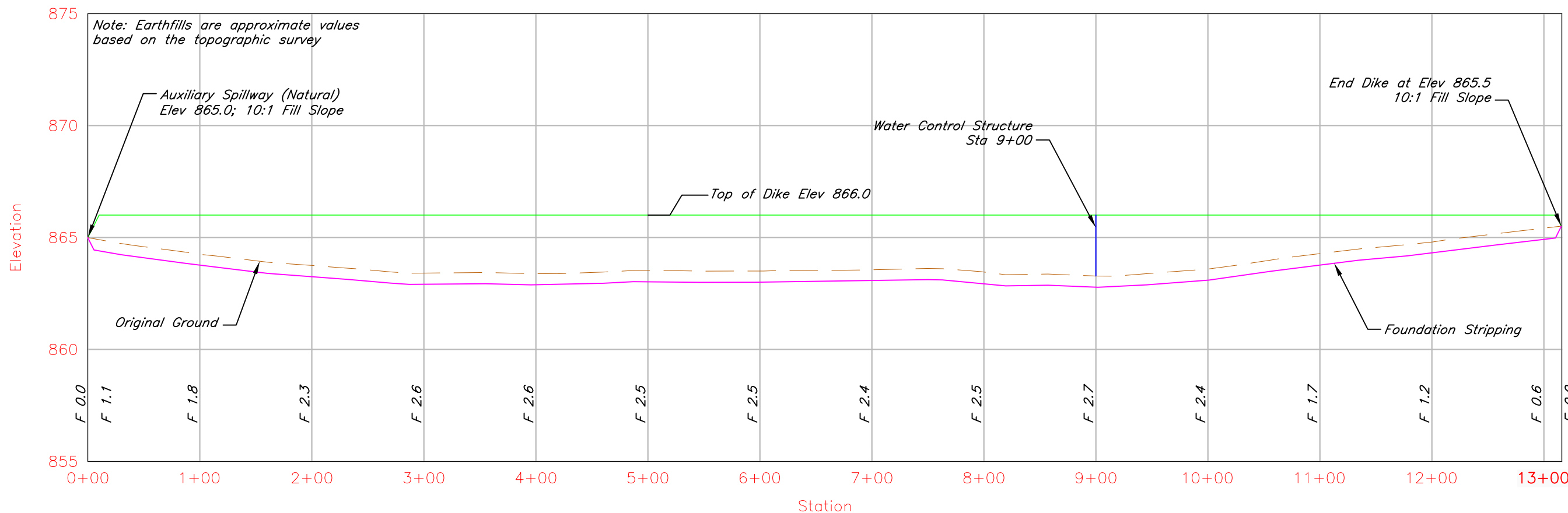

Profile View of Dike 1

Dike 1 Detail

Date 06/18  
 Designed B Severin  
 Drawn B Severin  
 Checked K Buntin  
 Approved B Severin

Dale & Joyce Ann Fultz Revocable Trust  
 ACEP - Wetland Reserve Easement  
 SE 1/4 Sec 30, T-31S; R-20E  
 Labette County, Kansas

United States  
 Department of  
 Agriculture  
**USDA**  
 Natural Resources  
 Conservation Service

Drawing Name  
 fultz30  
 6/25/18 2:02 PM  
 Sheet 6 of 18

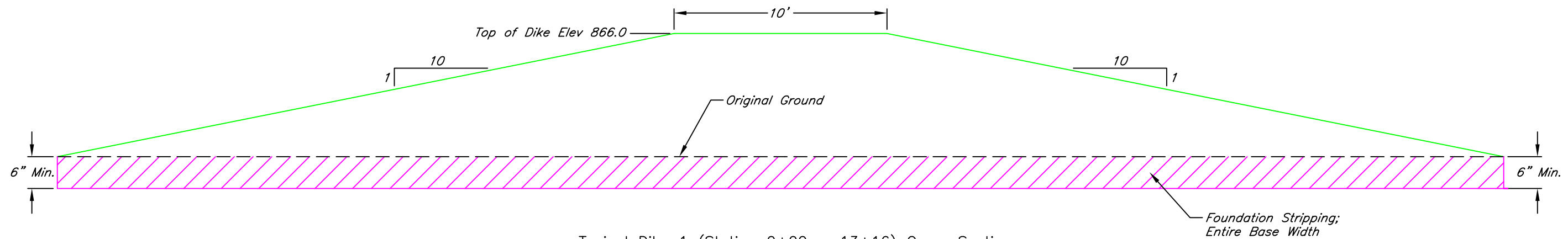

Typical Dike 1 (Station 0+00 - 13+16) Cross Section

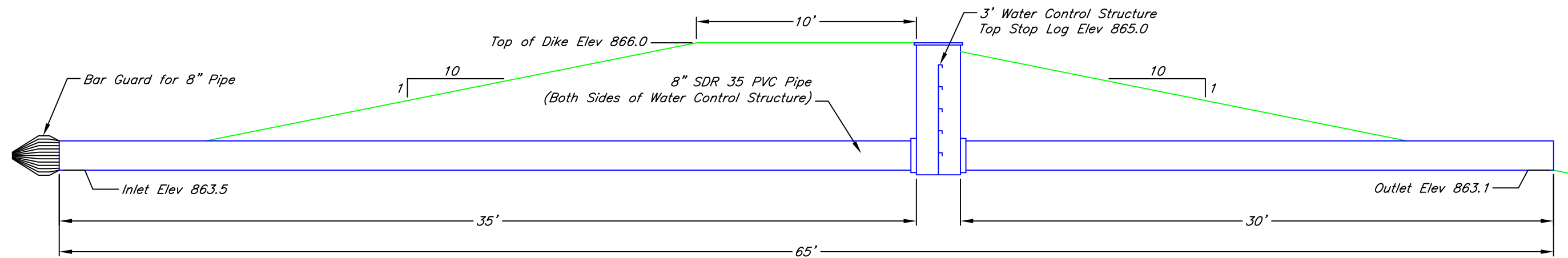

Dike 1 Water Control Structure (Station 9+00) Cross Section

Station	Original Ground Elev	Design Elev	As-Built Elev	Station	Original Ground Elev	Design Elev	As-Built Elev
0+00		865.0		8+00		866.0	
0+10		866.0		9+00		866.0	
1+00		866.0		10+00		866.0	
2+00		866.0		11+00		866.0	
3+00		866.0		12+00		866.0	
4+00		866.0		13+00		866.0	
5+00		866.0		13+11		866.0	
6+00		866.0		13+16		865.5	
7+00		866.0					

Item	Unit	Design Quantity	As-Built Quantity
8" SDR 35 PVC Pipe	lin ft	65	
Bar Guard, 8" Dia. Pipe	each	1	
3' Water Control Structure	each	1	

Date 06/18  
 Designed B Severin  
 Drawn B Severin  
 Checked K Buntin  
 Approved B Severin

Dale & Joyce Ann Fultz Revocable Trust  
 ACEP - Wetland Reserve Easement  
 SE 1/4 Sec 30, T-31S; R-20E  
 Labette County, Kansas

United States Department of Agriculture  
 Natural Resources Conservation Service

Drawing Name fultz30  
 6/25/18 2:02 PM  
 Sheet 7 of 18

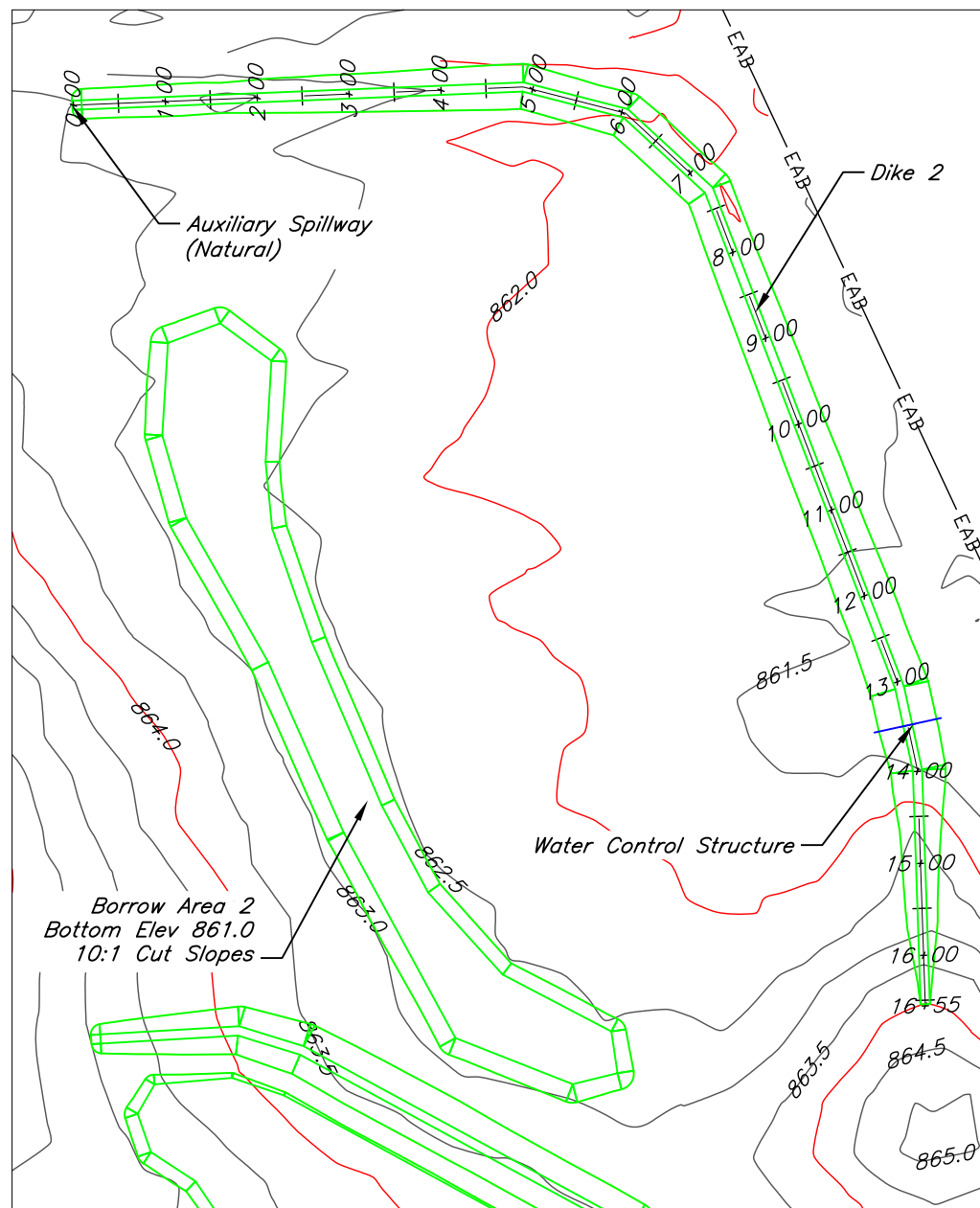

Elevation (ft)	Area (ac)	Total Storage (ac-ft)
861.5	0.57	0.06
862.0	5.89	1.67
862.5	11.14	5.93
ASW 863.0	16.01	12.72
863.5	19.28	21.54
TOD 864.0	20.91	31.59

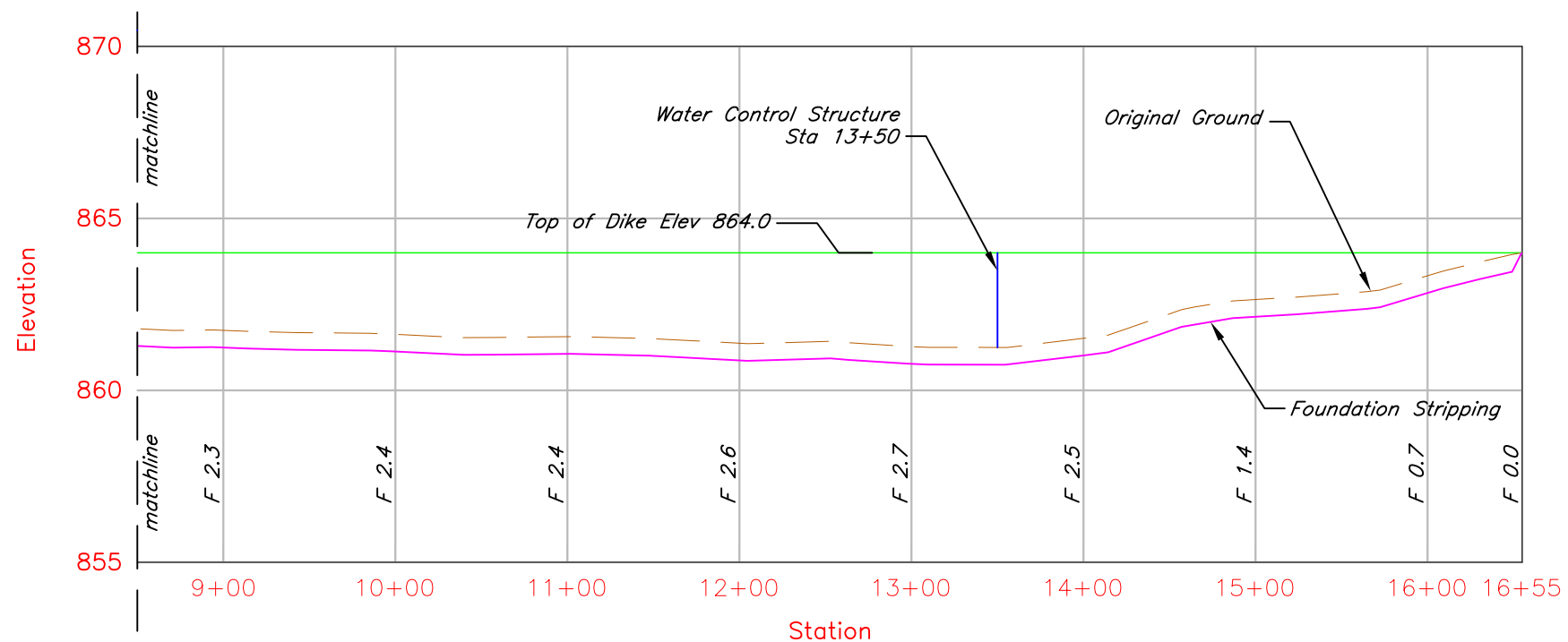
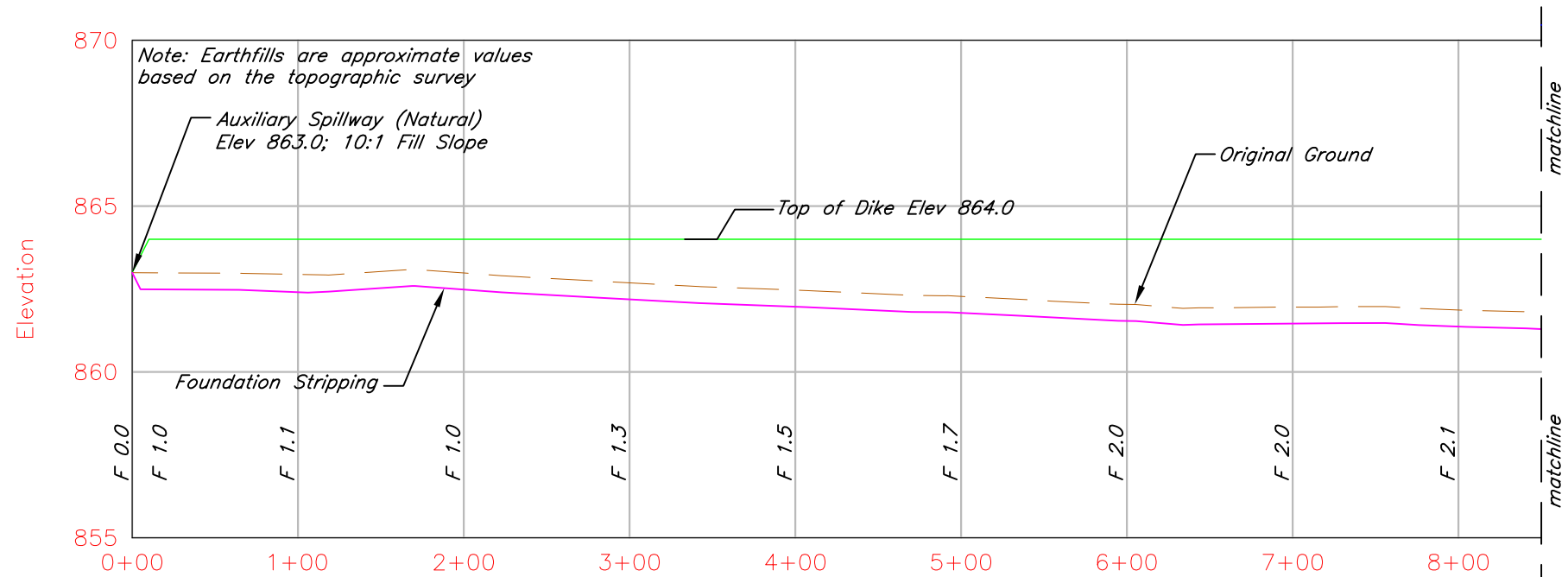

Profile View of Dike 2

Date 06/18  
 Designed B Severin  
 Drawn B Severin  
 Checked K Buntin  
 Approved B Severin

Dale & Joyce Ann Fultz Revocable Trust  
 ACEP - Wetland Reserve Easement  
 SE 1/4 Sec 30, T-31S; R-20E  
 Labette County, Kansas



Drawing Name fultz30  
6/25/18 2:02 PM  
 Sheet 8 of 18

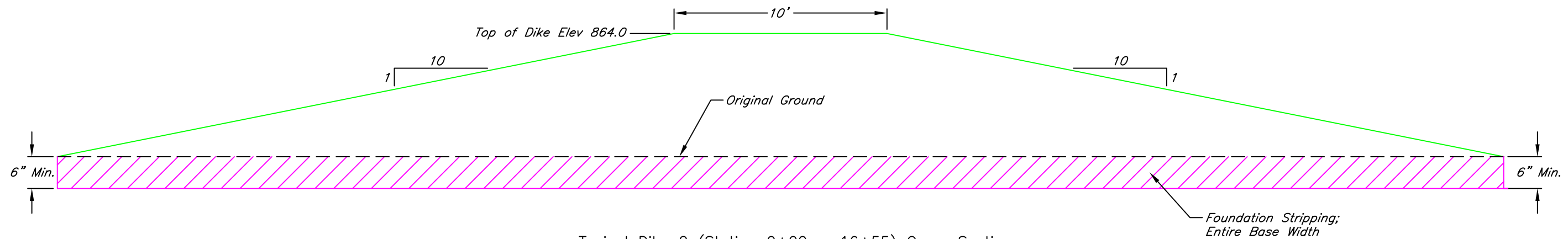

Typical Dike 2 (Station 0+00 - 16+55) Cross Section

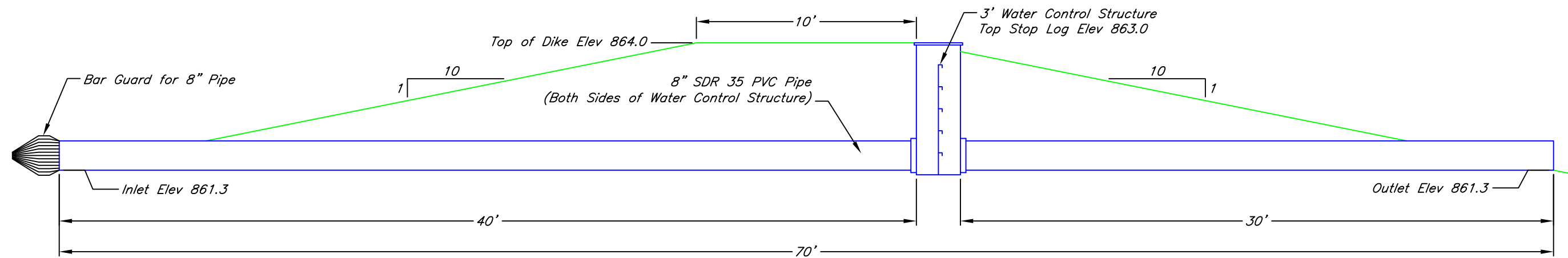

Dike 2 Water Control Structure (Station 13+50) Cross Section

Station	Original Ground Elev	Design Elev	As-Built Elev	Station	Original Ground Elev	Design Elev	As-Built Elev
0+00		863.0		9+00		864.0	
0+10		864.0		10+00		864.0	
1+00		864.0		11+00		864.0	
2+00		864.0		12+00		864.0	
3+00		864.0		13+00		864.0	
4+00		864.0		14+00		864.0	
5+00		864.0		15+00		864.0	
6+00		864.0		16+00		864.0	
7+00		864.0		16+55		864.0	
8+00		864.0					

Item	Unit	Design Quantity	As-Built Quantity
8" SDR 35 PVC Pipe	lin ft	70	
Bar Guard, 8" Dia. Pipe	each	1	
3' Water Control Structure	each	1	

Date 06/18  
 Designed B Severin  
 Drawn B Severin  
 Checked K Buntin  
 Approved B Severin

Dale & Joyce Ann Fultz Revocable Trust  
 ACEP - Wetland Reserve Easement  
 SE 1/4 Sec 30, T-31S; R-20E  
 Labette County, Kansas

United States Department of Agriculture  
 USDA  
 Natural Resources Conservation Service

Drawing Name fultz30  
 6/25/18 2:02 PM  
 Sheet 9 of 18

Dike 2 Detail



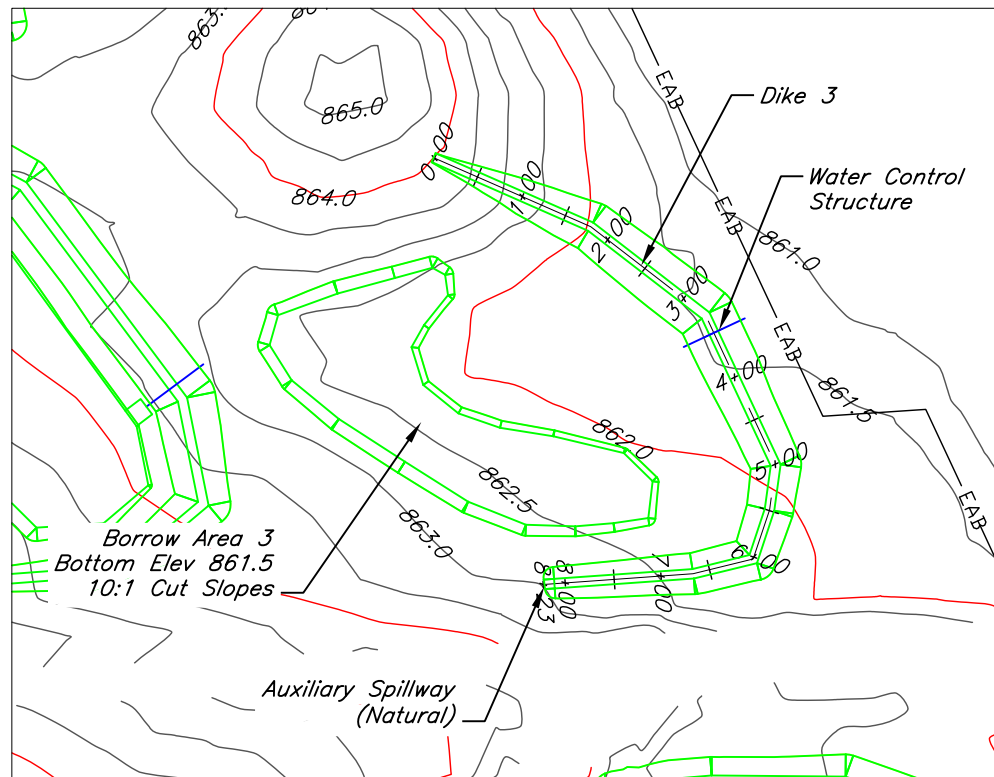

Elevation (ft)	Area (ac)	Total Storage (ac-ft)
861.5	0.00	0.00
862.0	1.00	0.25
862.5	2.44	1.11
ASW 863.0	3.63	2.63
863.5	4.59	4.68
TOD 864.0	5.31	7.16

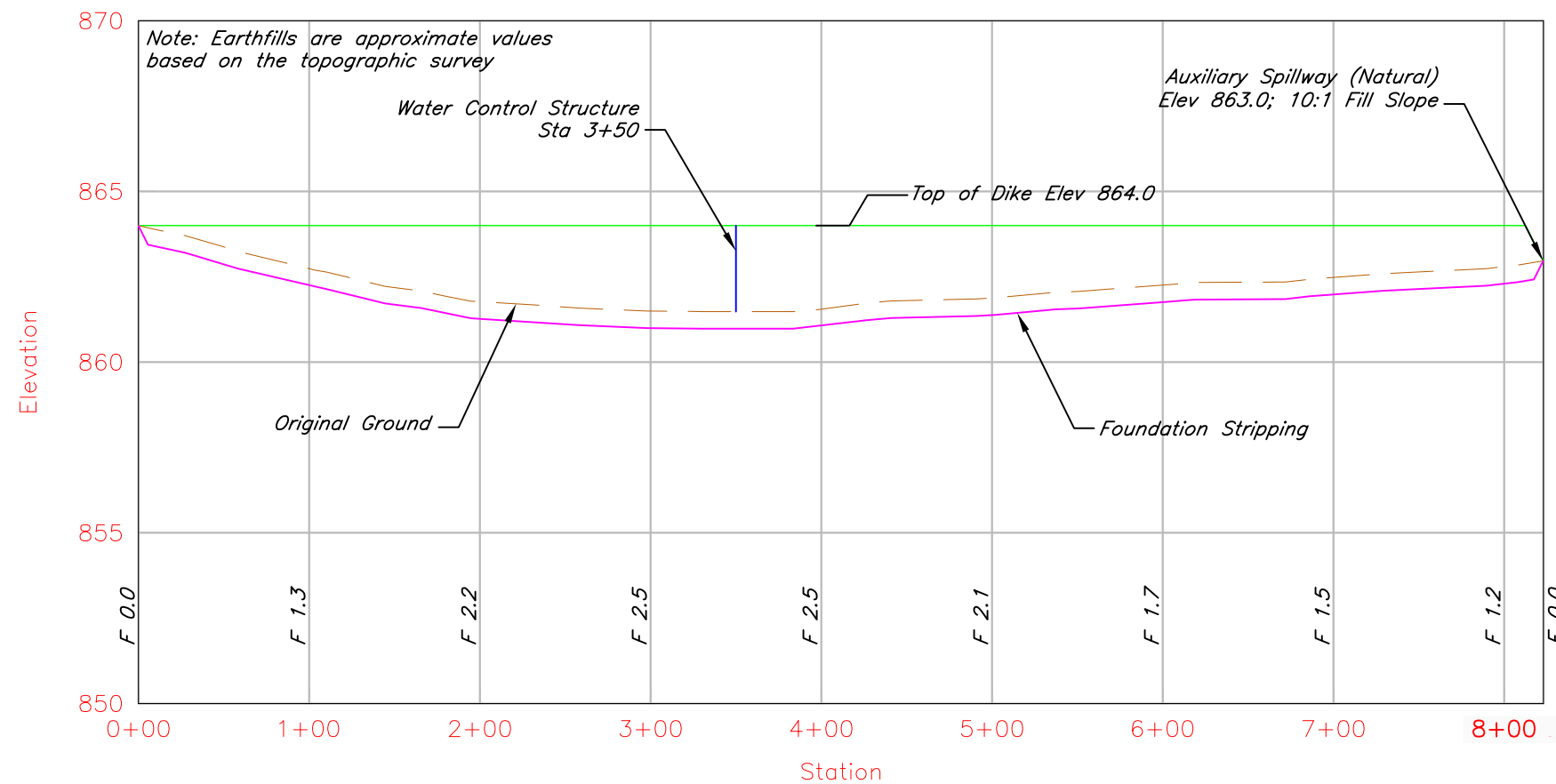

Profile View of Dike 3

Dale & Joyce Ann Fultz Revocable Trust  
 ACEP - Wetland Reserve Easement  
 SE 1/4 Sec 30, T-31S; R-20E  
 Labette County, Kansas

Designed B Severin Date 06/18  
 Drawn B Severin 06/18  
 Checked K Buntin 06/18  
 Approved 06/18

United States  
 Department of  
 Agriculture  
**USDA**  
 Natural Resources  
 Conservation Service

Drawing Name  
 fultz30  
 6/25/18 2:02 PM  
 Sheet 10 of 18

Dike 3 Detail

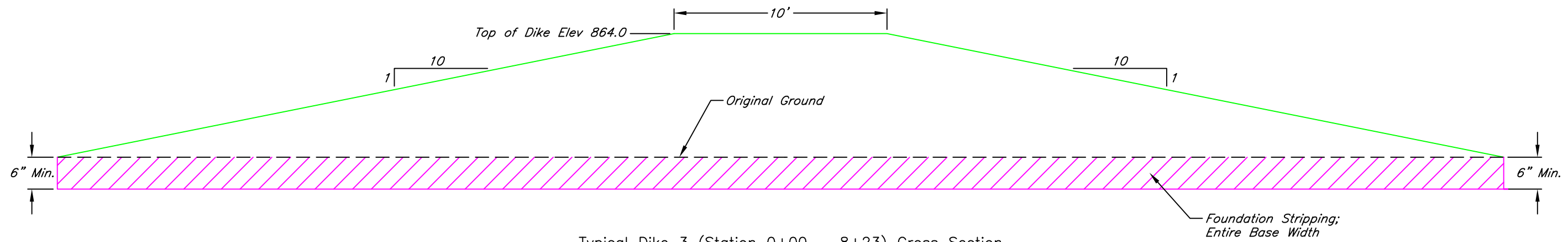

Typical Dike 3 (Station 0+00 - 8+23) Cross Section

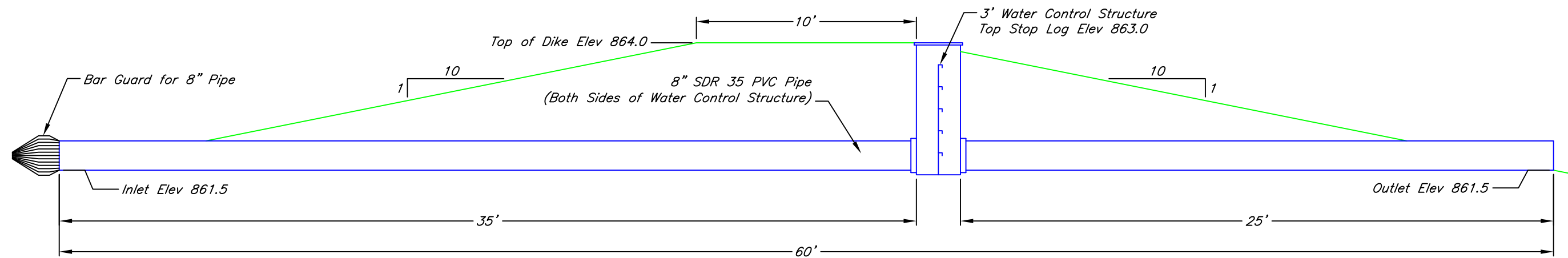

Dike 3 Water Control Structure (Station 3+50) Cross Section

Dike 3 (Centerline) Checkout Table			
Station	Original Ground Elev	Design Elev	As-Built Elev
0+00		864.0	
1+00		864.0	
2+00		864.0	
3+00		864.0	
4+00		864.0	
5+00		864.0	
6+00		864.0	
7+00		864.0	
8+00		864.0	
8+13		864.0	
8+23		863.0	

Dike 3 Water Control Structure Checkout Table			
Item	Unit	Design Quantity	As-Built Quantity
8" SDR 35 PVC Pipe	lin ft	60	
Bar Guard, 8" Dia. Pipe	each	1	
3' Water Control Structure	each	1	

Date 06/18  
 Designed B Severin  
 Drawn B Severin  
 Checked K Buntin  
 Approved B Severin

Dale & Joyce Ann Fultz Revocable Trust  
 ACEP - Wetland Reserve Easement  
 SE 1/4 Sec 30, T-31S; R-20E  
 Labette County, Kansas

United States  
 Department of  
 Agriculture  
**USDA**  
 Natural Resources  
 Conservation Service

Drawing Name  
 fultz30  
 6/25/18 2:02 PM  
 Sheet 11 of 18

Dike 3 Detail

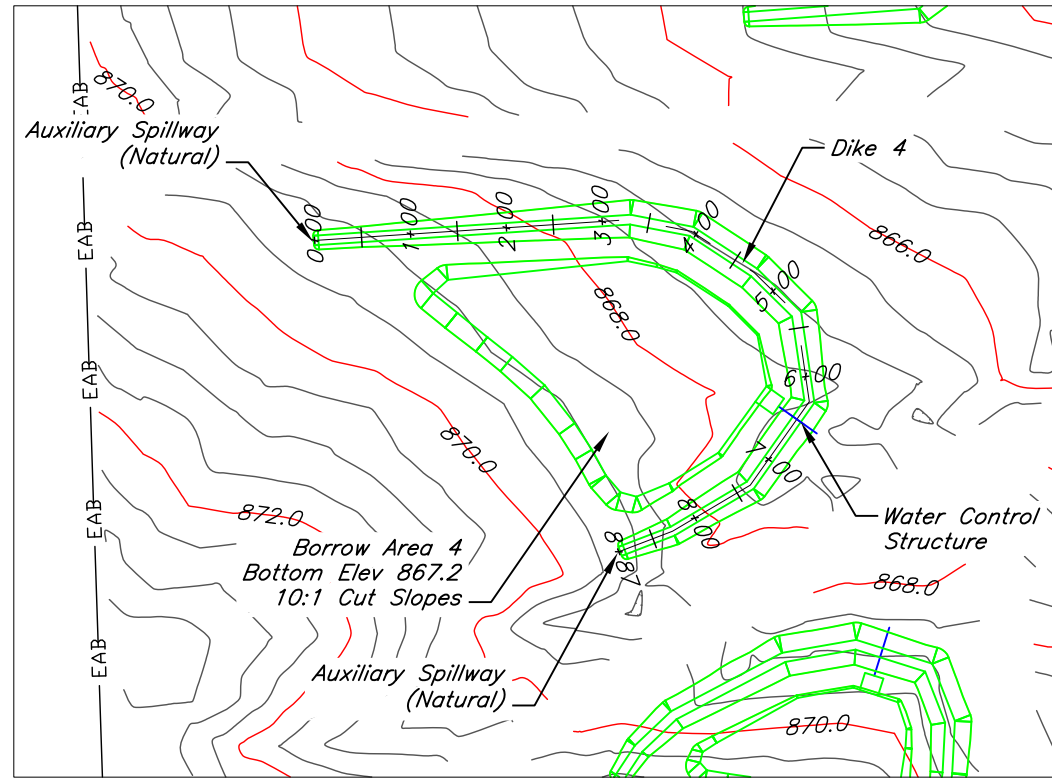

Elevation (ft)	Area (ac)	Total Storage (ac-ft)
867.5	0.30	0.08
868.0	0.86	0.37
868.5	1.40	0.93
ASW 869.2	2.11	2.16
869.5	2.43	2.84
TOD 870.2	3.28	4.84

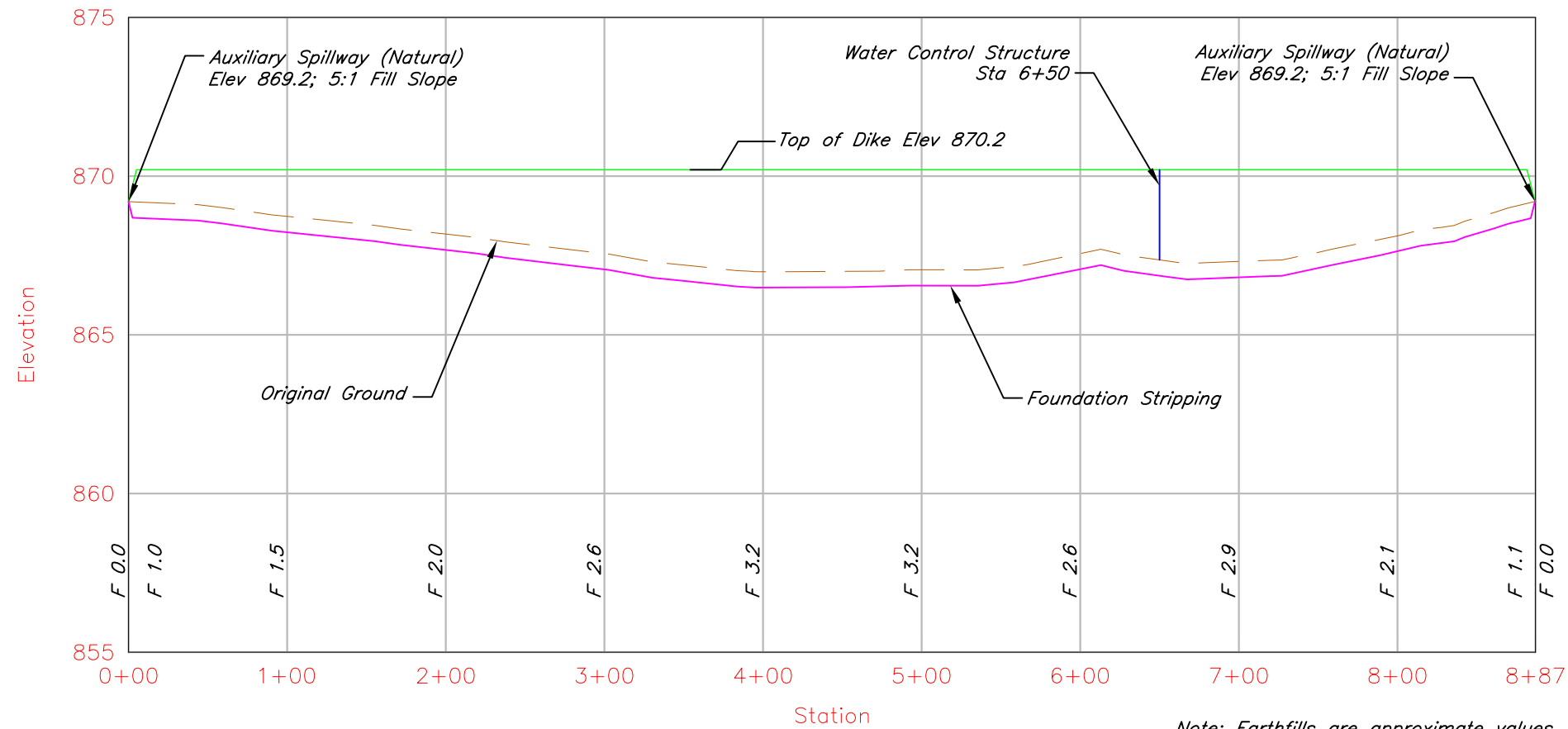

Profile View of Dike 4

Note: Earthfills are approximate values based on the topographic survey

Date 06/18  
 Designed B Severin  
 Drawn B Severin  
 Checked K Buntin  
 Approved 06/18

Dale & Joyce Ann Fultz Revocable Trust  
 ACEP - Wetland Reserve Easement  
 SE 1/4 Sec 30, T-31S; R-20E  
 Labette County, Kansas

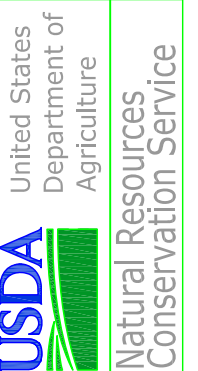

Drawing Name fultz30  
6/25/18 2:02 PM  
 Sheet 12 of 18

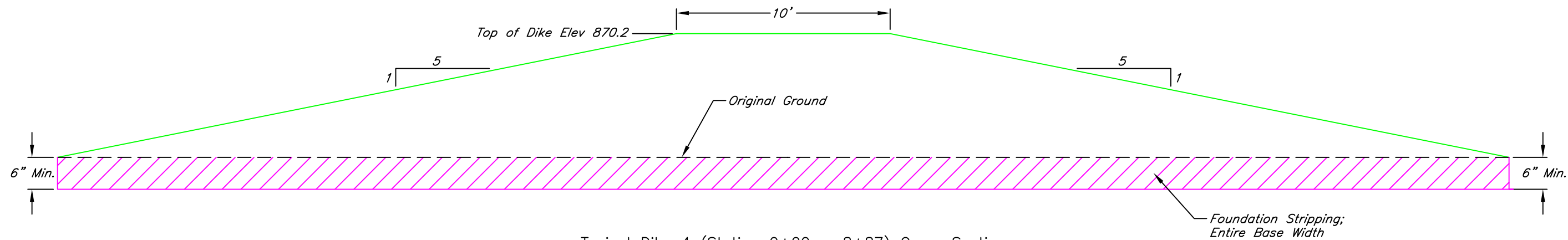

Typical Dike 4 (Station 0+00 - 8+87) Cross Section

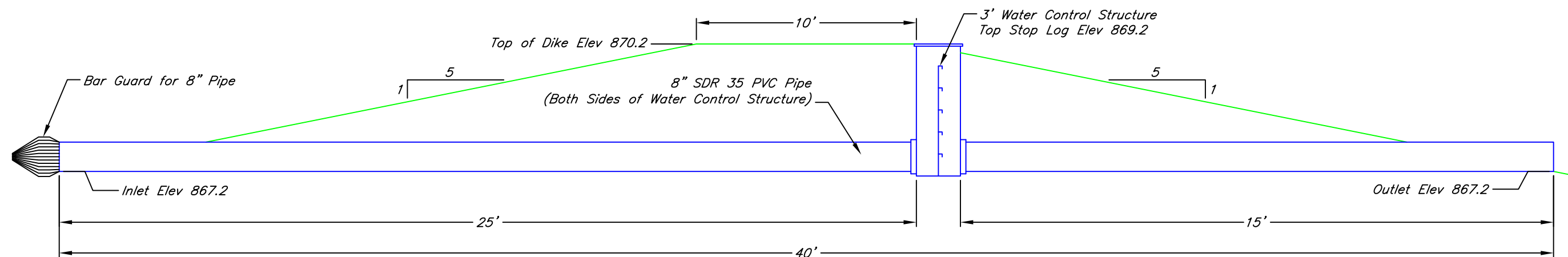

Dike 4 Water Control Structure (Station 6+50) Cross Section

Station	Original Ground Elev	Design Elev	As-Built Elev
0+00		869.2	
0+10		870.2	
1+00		870.2	
2+00		870.2	
3+00		870.2	
4+00		870.2	
5+00		870.2	
6+00		870.2	
7+00		870.2	
8+00		870.2	
8+77		870.2	
8+87		869.2	

Item	Unit	Design Quantity	As-Built Quantity
8" SDR 35 PVC Pipe	lin ft	40	
Bar Guard, 8" Dia. Pipe	each	1	
3' Water Control Structure	each	1	

Date 06/18  
 Designed B Severin  
 Drawn B Severin  
 Checked K Buntin  
 Approved B Severin

Dale & Joyce Ann Fultz Revocable Trust  
 ACEP - Wetland Reserve Easement  
 SE 1/4 Sec 30, T-31S; R-20E  
 Labette County, Kansas



Drawing Name fultz30  
 6/25/18 2:02 PM  
 Sheet 13 of 18

Dike 4 Detail

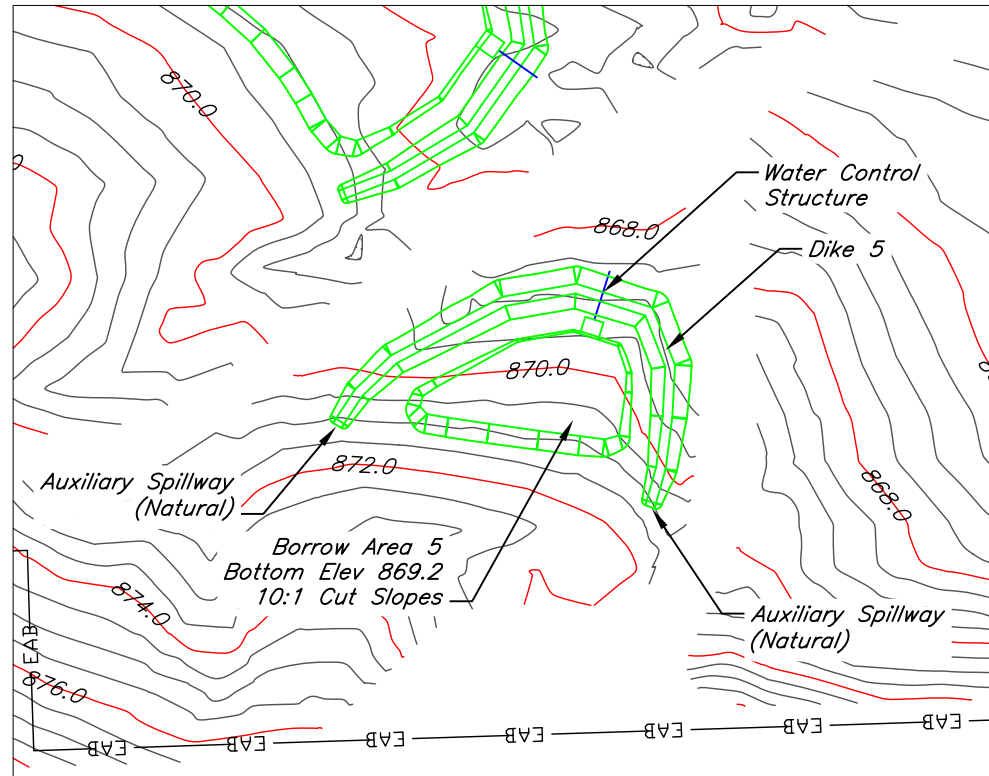

**Dike 5 Stage Storage Table**

Elevation (ft)	Area (ac)	Total Storage (ac-ft)
869.5	0.23	0.06
870.0	0.48	0.24
870.5	0.71	0.53
ASW 871.2	1.02	1.14
871.5	1.13	1.46
TOD 872.2	1.41	2.35

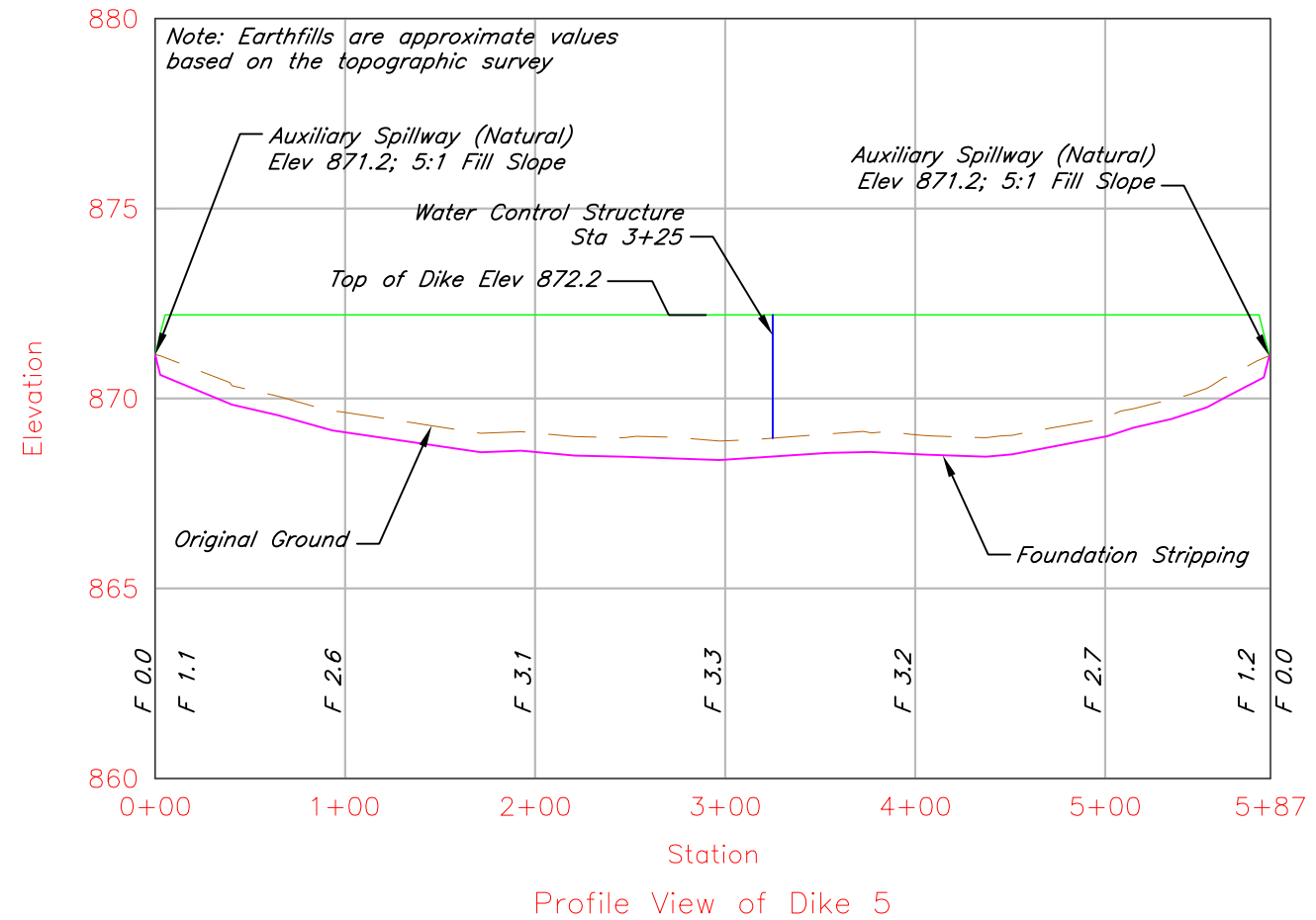

Date 06/18  
 Designed B Severin  
 Drawn B Severin  
 Checked K Buntin  
 Approved 06/18

Dale & Joyce Ann Fultz Revocable Trust  
 ACEP - Wetland Reserve Easement  
 SE 1/4 Sec 30, T-31S; R-20E  
 Labette County, Kansas



Drawing Name  
 fultz30  
 6/25/18 2:02 PM  
 Sheet 14 of 18

Dike 5 Detail

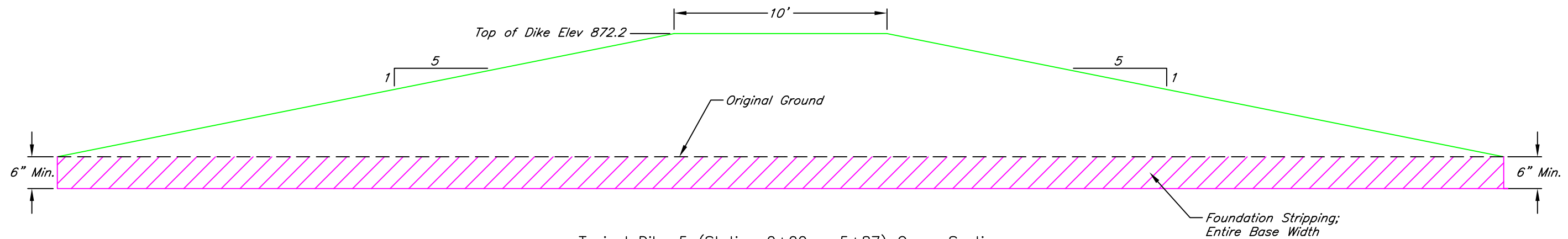

Typical Dike 5 (Station 0+00 - 5+87) Cross Section

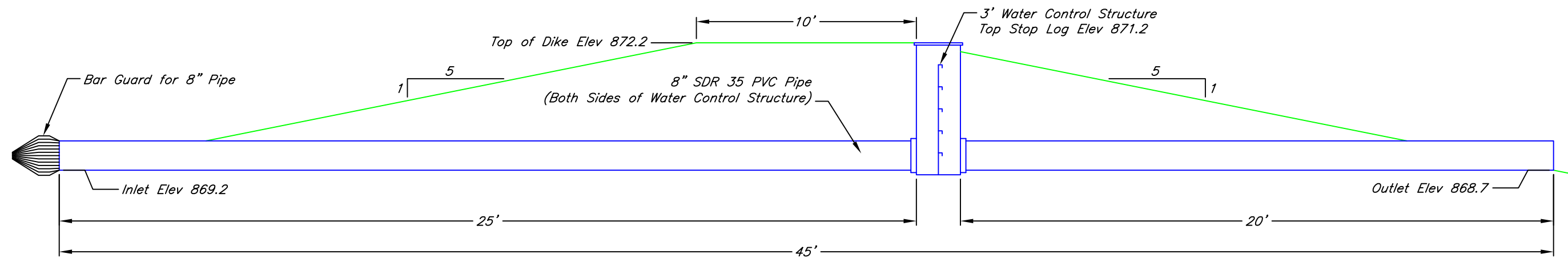

Dike 5 Water Control Structure (Station 3+25) Cross Section

Station	Original Ground Elev	Design Elev	As-Built Elev
0+00		871.2	
0+10		872.2	
1+00		872.2	
2+00		872.2	
3+00		872.2	
4+00		872.2	
5+00		872.2	
5+77		872.2	
5+87		871.2	

Item	Unit	Design Quantity	As-Built Quantity
8" SDR 35 PVC Pipe	lin ft	45	
Bar Guard, 8" Dia. Pipe	each	1	
3' Water Control Structure	each	1	

Date 06/18  
 Designed B Severin  
 Drawn B Severin  
 Checked K Buntin  
 Approved B Severin

Dale & Joyce Ann Fultz Revocable Trust  
 ACEP - Wetland Reserve Easement  
 SE 1/4 Sec 30, T-31S; R-20E  
 Labette County, Kansas

United States  
 Department of  
 Agriculture  
**USDA**  
 Natural Resources  
 Conservation Service

Drawing Name  
 fultz30  
 6/25/18 2:02 PM  
 Sheet 15 of 18

Dike 5 Detail

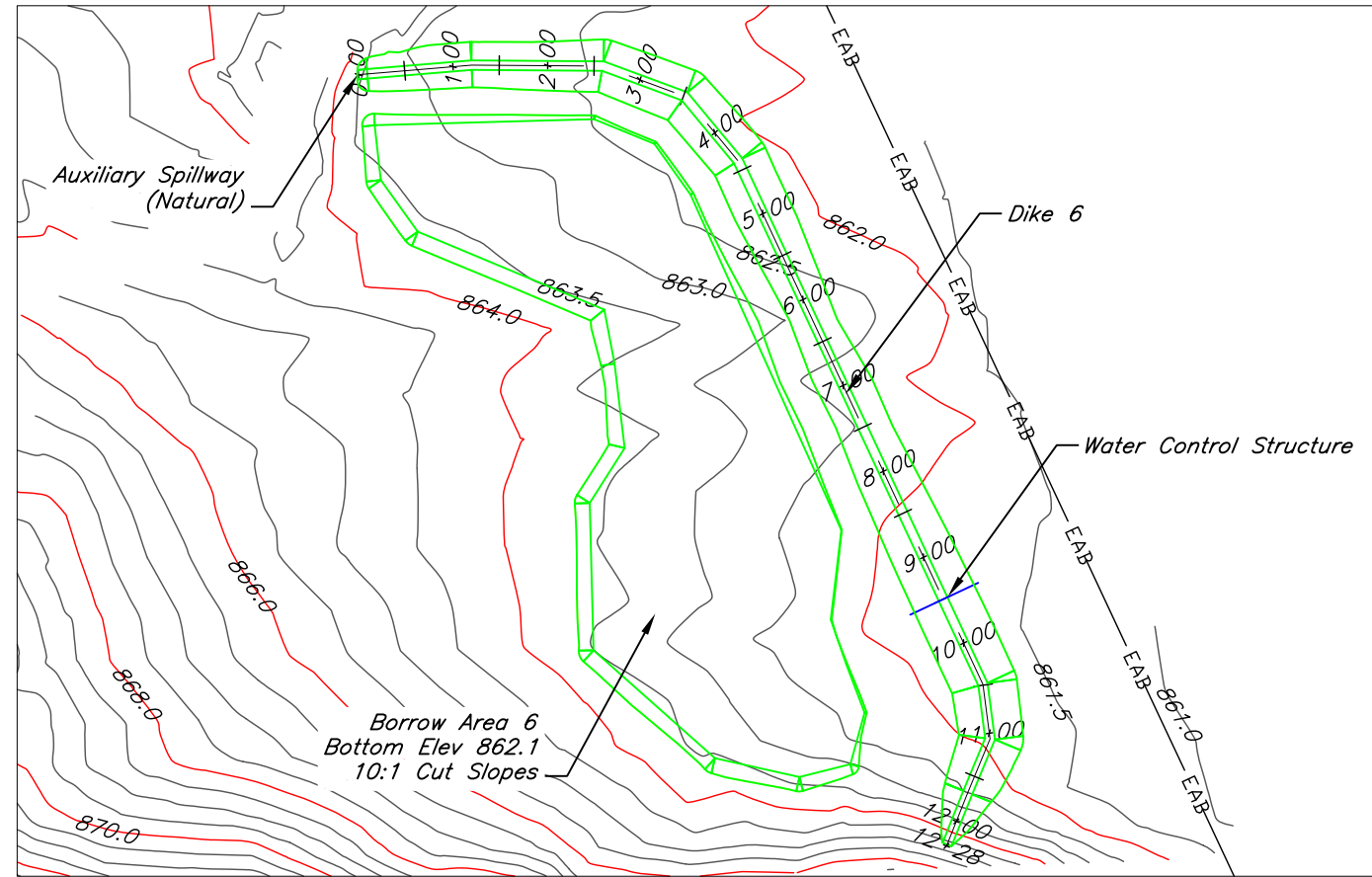

Elevation (ft)	Area (ac)	Total Storage (ac-ft)
862.0	0.34	0.02
862.5	1.58	0.50
863.0	3.50	1.77
ASW 863.7	6.00	5.09
864.0	7.15	7.06
TOD 864.7	9.20	12.79

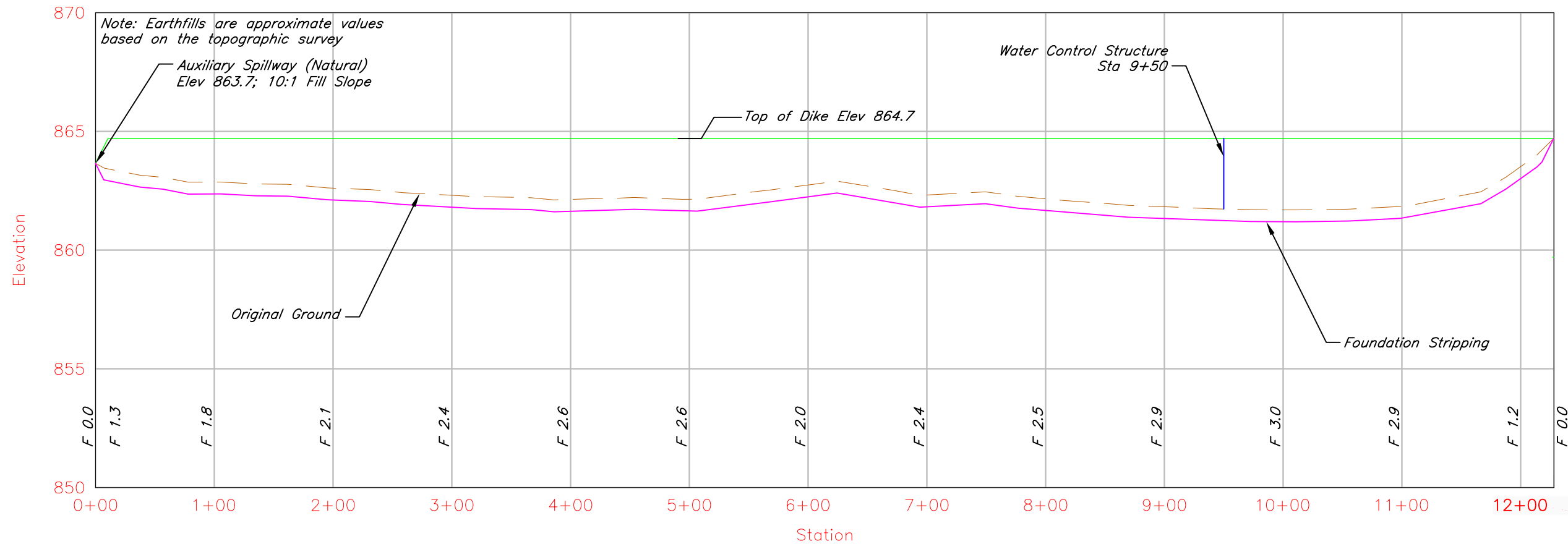

Profile View of Dike 6

Date 06/18  
 Designed B Severin  
 Drawn B Severin  
 Checked K Buntin  
 Approved B Severin

Dale & Joyce Ann Fultz Revocable Trust  
 ACEP - Wetland Reserve Easement  
 SE 1/4 Sec 30, T-31S; R-20E  
 Labette County, Kansas

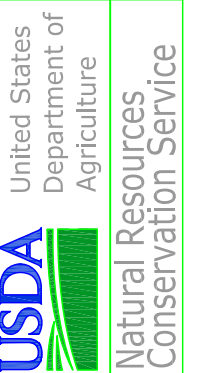

Drawing Name fultz30  
6/25/18 2:02 PM  
 Sheet 16 of 18

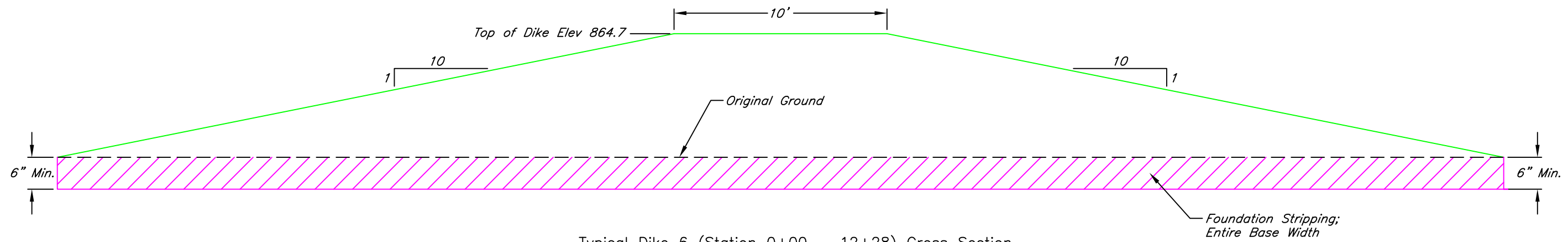

Typical Dike 6 (Station 0+00 - 12+28) Cross Section

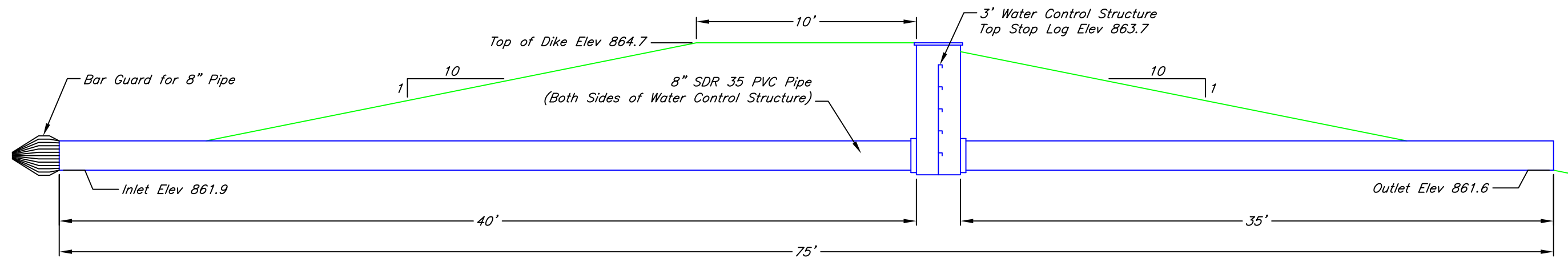

Dike 6 Water Control Structure (Station 9+50) Cross Section

Station	Original Ground Elev	Design Elev	As-Built Elev	Station	Original Ground Elev	Design Elev	As-Built Elev
0+00		863.7		7+00		864.7	
0+10		864.7		8+00		864.7	
1+00		864.7		9+00		864.7	
2+00		864.7		10+00		864.7	
3+00		864.7		11+00		864.7	
4+00		864.7		12+00		864.7	
5+00		864.7		12+28		864.7	
6+00		864.7					

Item	Unit	Design Quantity	As-Built Quantity
8" SDR 35 PVC Pipe	lin ft	75	
Bar Guard, 8" Dia. Pipe	each	1	
3' Water Control Structure	each	1	

Date 06/18  
 Designed B Severin  
 Drawn B Severin  
 Checked K Buntin  
 Approved B Severin

Dale & Joyce Ann Fultz Revocable Trust  
 ACEP - Wetland Reserve Easement  
 SE 1/4 Sec 30, T-31S; R-20E  
 Labette County, Kansas

United States  
 Department of  
 Agriculture  
 USDA  
 Natural Resources  
 Conservation Service

Drawing Name  
 fultz30  
 6/25/18 2:02 PM  
 Sheet 17 of 18



Date	06/18	Designed	B Severin
	06/18	Drawn	B Severin
	06/18	Checked	K Buntin
	06/18	Approved	B Severin

Seeding Plan Map

Dale & Joyce Ann Fultz Revocable Trust  
 ACEP - Wetland Reserve Easement  
 SE 1/4 Sec 30, T-31S; R-20E  
 Labette County, Kansas

United States  
 Department of  
 Agriculture  
**USDA**  
 Natural Resources  
 Conservation Service

Drawing Name  
**FULTZ 30**  
 6/23/18 2:02 PM  
 Sheet 18 of 18

Scale in Feet  
 400 0 400 800



Notes:  
 1. Range Planting area shall be disked (multiple passes) prior to drilling native seed. See Construction Specification 266 - Range Planting.  
 2. Chemical Weed Control shall be applied to the Range Planting area (excludes the Wetland Permanent Pool Area). Total Area of Chemical Application = 74.3 acres

## Hemphill, Lloyd [KDA]

---

**From:** bobbyglover97@gmail.com  
**Sent:** Monday, June 26, 2023 5:27 PM  
**To:** Hemphill, Lloyd [KDA]  
**Subject:** Re: Application File Nos. 50795 & 50897: Fultz Wetland

**EXTERNAL:** This email originated from outside of the organization. Do not click any links or open any attachments unless you trust the sender and know the content is safe.

Lloyd  
That amt is sufficient for fultz. I am mailing the access document today  
Thanks  
Bobby Glover

Sent from my iPhone

On Jun 26, 2023, at 12:15 PM, Hemphill, Lloyd [KDA] <Lloyd.Hemphill@ks.gov> wrote:

Good Afternoon,

Additional information is needed to finish processing these water appropriation applications related to the Fultz Wetland (SE¼ Sec 30, T31S, R20E, LB CO, KS).

For Application, [File No. 50,795](#), evidence of legal access to or control of, the point of diversion (pumpsite) must be provided in paragraph 6 of the application. In lieu of providing legal ownership documents, the attached sworn statement may be signed indicating legal access. You may either return a good quality color scan (not a photograph) of this signed statement by e-mail or mail the original to me at the Topeka Field Office at:

Topeka Field Office  
1131 SW Winding Rd, Suite 400  
Topeka, KS 66615

Based on previous e-mail conversations it appears that the intent for this project is to have the ability to fill the wetland three times and also cover annual net evaporation. It appears that that the water level will be maintained at or below the auxilliary elevation.

The combined surface area and capacity of the six wetland pools at spillway elevation is 33.5 acres and 27.4 acre-feet. The pools in the micro-depression area appear to cover about 1.25 acres surface area and likely have no more than 2 acre-feet of storage. This makes a final surface area of 34.7 acres and storage of 29.4 acre-feet. The quantity of water would be calculated as follows:

3 X storage = 29.4 acre-feet X 3 = **88.2 acre-feet**  
Net evaporation = 6 inches/year/12 X 34.7 acres surface area = **17.4 acre-feet**  
Total Quantity = 88.2 acre-feet + 17.4 acre-feet = **105.6 acre-feet**

If you anticipate additional losses while filling the wetland not covered by these numbers, we recommend that you add this to the 105.6 acre-feet.

Application, File No. 50,795 will cover the water pumped from the creek (i.e. supplement precipitation/runoff) and Application, File No. 50,897 will be modified to cover the collection of natural flows/runoff. As calculated above, the requested quantity for each application will be 105.6 acre-feet so that either source of water may be used as available. Both permits will be limited to this quantity when used in combination.

**If this quantity will not be sufficient for this project, please provide additional information.** Additional water may be allowed with justification.

Please reply with confirmation of the requested quantity of water.

If you have any questions, you may contact me by e-mail or by phone at (785) 296-8682.

Thanks,

Lloyd

Lloyd Hemphill, Environmental Scientist  
Kansas Department of Agriculture  
Division of Water Resources, Topeka Field Office  
1131 SW Winding Rd, Suite 400  
Topeka, KS 66615  
Office: (785) 296-5733

<Legal Access Signature Block.pdf>

THE STATE OF KANSAS



KANSAS DEPARTMENT OF AGRICULTURE  
Mike Beam, Secretary of Agriculture

DIVISION OF WATER RESOURCES  
Earl D. Lewis Jr., Chief Engineer

APPROVAL OF APPLICATION  
and  
PERMIT TO PROCEED

(This Is Not a Certificate of Appropriation)

This is to certify that I have examined Application, **File No. 50,795** of the applicant

GLOVER REAL ESTATE LLC  
2479 US HWY 400  
MCCUNE, KS 66753

for a permit to appropriate water for beneficial use, together with the maps, plans and other submitted data, and that the application is hereby approved and the applicant is hereby authorized, subject to vested rights and prior appropriations, to proceed with the construction of the proposed diversion works (except those dams and stream obstructions regulated by K.S.A. 82a-301 through 305a, as amended), and to proceed with all steps necessary for the application of the water to the approved and proposed beneficial use and otherwise perfect the proposed appropriation subject to the following terms, conditions and limitations:

1. That the priority date assigned to such application is **May 25, 2022**.
2. That the water sought to be appropriated shall be used for recreational use in a marsh located in the Southeast Quarter (SE $\frac{1}{4}$ ) and the Southwest Quarter of the Northeast Quarter (SW $\frac{1}{4}$  NE $\frac{1}{4}$ ) of Section 30, in Township 31 South, Range 20 East, Labette County, Kansas.
3. That the authorized source from which the appropriation shall be made is surface water from Little Labette Creek (Neosho River), to be withdrawn by means of one (1) pump site located in the Northwest Quarter of the Southwest Quarter of the Northeast Quarter (NW $\frac{1}{4}$  SW $\frac{1}{4}$  NE $\frac{1}{4}$ ) of Section 30, more particularly described as being near a point 3,930 feet North and 2,037 feet West of the Southeast corner of said section, all in Township 31 South, Range 20 East, Labette County, Kansas, located substantially as shown on the map accompanying the application.
4. That the appropriation sought shall be limited to a maximum diversion rate not in excess of **10,000 gallons per minute (22.28 c.f.s.)** and to a quantity not to exceed **106 acre-feet** of water for any calendar year.
5. That installation of works for diversion of water shall be completed on or before **December 31, 2024** or within any authorized extension thereof. The applicant shall notify the Chief Engineer and pay the statutorily required field inspection fee of \$400.00 when construction of the works has been completed. Failure to timely submit the notice and the fee will result in revocation of the permit. Any request for an extension of time shall be submitted prior to the expiration of the deadline and shall be accompanied by the required statutory fee of \$100.00.
6. That the proposed appropriation shall be perfected by the actual application of water to the proposed beneficial use on or before **December 31, 2028** or any authorized extension thereof. Any request for an extension of time shall be submitted prior to the expiration of the deadline and shall be accompanied by the required statutory fee of \$100.00.

7. That the applicant shall not be deemed to have acquired a water appropriation for a quantity in excess of the amount approved herein nor in excess of the amount found by the Chief Engineer to have been actually used for the approved purpose during one calendar year subsequent to approval of the application and within the time specified for perfection or any authorized extension thereof.

8. That the use of water herein authorized shall not be made so as to impair any use under existing water rights nor prejudicially and unreasonably affect the public interest.

9. That the right of the appropriator shall relate to a specific quantity of water and such right must allow for a reasonable raising or lowering of the static water level and for the reasonable increase or decrease of the streamflow at the appropriator's point of diversion.

10. That this permit does not constitute authority under K.S.A. 82a-301 through 305a to construct any dam or other obstruction; nor does it grant any right-of-way, or authorize entry upon or injury to, public or private property.

11. That all diversion works constructed under the authority of this permit into which any type of chemical or other foreign substance will be injected into the water pumped from the diversion works shall be equipped with an in-line, automatic quick-closing, check valve capable of preventing pollution of the source of the water supply. The type of valve installed shall meet specifications adopted by the Chief Engineer and shall be maintained in an operating condition satisfactory to the Chief Engineer.

12. That an acceptable water flow meter shall be installed and maintained on the diversion works authorized by this permit in accordance with the Kansas Administrative Regulations 5-1-4 through 5-1-12 adopted by the Chief Engineer. This water flow meter shall be used to provide an accurate quantity of water diverted as required for the annual water use report (including the meter reading at the beginning and end of the report year).

13. That the applicant shall maintain accurate and complete records from which the quantity of water diverted during each calendar year may be readily determined and the applicant shall file an annual water use report with the Chief Engineer by March 1 following the end of each calendar year. Failure to file the annual water use report by the due date shall cause the applicant to be subject to a civil penalty.

14. That no water user shall engage in nor allow the waste of any water diverted under the authority of this permit.

15. That failure without cause to comply with provisions of the permit and its terms, conditions and limitations will result in the forfeiture of the priority date, revocation of the permit and dismissal of the application.

16. That the right to appropriate water under authority of this permit is subject to any minimum desirable streamflow requirements identified and established pursuant to K.S.A. 82a-703c for the source of supply to which this water right applies.

17. That diversion of natural flow shall not take place unless there is water available to satisfy all demands by senior water rights and permits.

18. That the stream flow shall not be stopped at the first riffle below the point of diversion while diversion is taking place under the authority of this water right or permit.

19. That during the period October 1 through June 30, the verbal or written permission of the Chief Engineer, or an authorized representative of the Chief Engineer, shall be obtained in order to divert water each time the applicant desires to divert water.

20. That during the period July 1 through September 30 each calendar year, no direct diversions of surface water shall be permitted unless written permission is obtained from the Chief Engineer, or the Chief Engineer's authorized representative.

Ordered this *28* day of *August*, 2023, in Manhattan, Riley County, Kansas.

*Lane P. Letourneau*

Lane P. Letourneau, P.G.  
Program Manager  
Water Appropriation Program  
Division of Water Resources  
Kansas Department of Agriculture

State of Kansas            )  
  ) SS  
County of Riley            )

The foregoing instrument was acknowledged before me this *28* day of *August*, 2023, by Lane P. Letourneau, P.G., Program Manager, Division of Water Resources, Kansas Department of Agriculture.

*Tony Jay Connors*

Notary Public

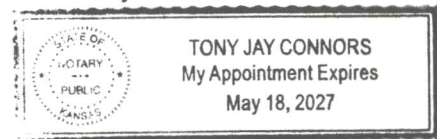

1320 Research Park Drive  
Manhattan, KS 66502  
785-564-6700  
www.agriculture.ks.gov



900 SW Jackson, Room 456  
Topeka, KS 66612  
785-296-3556

Mike Beam, Secretary

Laura Kelly, Governor

September 11, 2023

GLOVER REAL ESTATE LLC  
2479 US HWY 400  
MCCUNE, KS 66753

RE: Appropriation of Water, File Nos. 50,795 & 50,897

Dear Mr. Glover:

Enclosed are permits authorizing you to proceed with construction of the proposed diversion works and to appropriate water for beneficial use as set forth in these permits. Your attention is directed to the enclosures and to the terms, conditions, limitations, and requirements specified in these permits.

Notice must be filed on the enclosed form once the diversion works have been completed. Failure to complete the diversion works within the time allowed, or within any authorized extension of time thereof, will result in dismissal of the permit. If you need an extension of time, you must request it before the deadline for completion set forth in the permit. Any request for an extension of time must be accompanied by the statutorily required fee, which is currently \$100.00.

An acceptable water flowmeter must be installed on the diversion works authorized by File No. 50,795 prior to using water. An annual water use report must be filed with the Chief Engineer by March 1, following the end of each calendar year. If a complete annual water use report is not received by the deadline, then a fine may be assessed and all water use under such permit or right may be suspended. You may submit your report online for no fee at [www.kswaterusereport.org](http://www.kswaterusereport.org). Reports submitted in paper form will be assessed a \$20 per file number paper filing fee.

The approval of your applications constitutes a permit to appropriate water. It does not give authority to construct any dam or other stream obstruction regulated by K.S.A. 82a-301 through 305a. It does not give authority to access any right-of-way or authorize trespassing upon or injury to public or private property. It may also be necessary for you to comply with other local, state or federal requirements.

Enclosed is an informational sheet that sets forth the procedure to obtain a Certificate of Appropriation which will establish the extent of your perfected water right. Additional information is available on our website at [agriculture.ks.gov/divisions-programs/dwr](http://agriculture.ks.gov/divisions-programs/dwr). If you have any questions or need assistance, please contact our office at 785-564-6640 or the local Topeka Field Office at 785-296-5733. If you call, please reference the file number so we can help you more efficiently.

Sincerely,

Kristen A. Baum  
New Application Unit Supervisor  
Division of Water Resources

KAB:lh  
Enclosure(s)  
pc: Topeka Field Office

## RIGHT TO A HEARING AND TO ADMINISTRATIVE REVIEW

If you are aggrieved by this Order, then pursuant to K.S.A. 82a-1901, you may request an evidentiary hearing before the Chief Engineer, or request administrative review by the Secretary of Agriculture. Failure to request an evidentiary hearing before the Chief Engineer does not preclude your right to administrative review by the Secretary.

To obtain an evidentiary hearing before the Chief Engineer, a written request for hearing must be filed within 15 days after service of this Order as provided in K.S.A. 77-531 (**i.e., within a total of 18 days after this Order was mailed to you**), with: Kansas Department of Agriculture, Attn: Legal Division, 1320 Research Park Drive, Manhattan, Kansas 66502, FAX (785) 564-6777.

If you do not file a request for an evidentiary hearing before the Chief Engineer, you may petition for administrative review of the Order by the Secretary of Agriculture. A petition for review shall be in writing and state the basis for requesting administrative review. The request for review may be denied if the request fails to clearly establish factual or legal issues for review. See K.S.A. 77-527. The petition must be filed within 30 days after service of this Order as provided in K.S.A. 77-531 (**i.e., within a total of 33 days after this Order was mailed to you**), and be filed with: Secretary of Agriculture, Attn: Legal Division, Kansas Department of Agriculture, 1320 Research Park Drive, Manhattan, Kansas 66502, FAX (785) 564-6777.

If neither a request for an evidentiary hearing nor a petition for administrative review is filed as set forth above, then this Order shall be effective and become a final agency action as defined in K.S.A. 77-607(b). Failure to timely request either an evidentiary hearing or administrative review may preclude further judicial review under the Kansas Judicial Review

## CERTIFICATE OF SERVICE

On this 11 day of September, 2023, I hereby certify that the foregoing Approval of Application and Permit to Proceed, File Nos. 50,795 & 50,897 dated August 26, 2023, was mailed postage prepaid, first class, US mail to the following:

GLOVER REAL ESTATE LLC  
2479 US HWY 400  
MCCUNE, KS 66753

With photocopies to:

Topeka Field Office

  
\_\_\_\_\_  
Division of Water Resources